

Panasonic

Telephone Answering System
With Plain Paper Facsimile

Model No. **KX-F1100**

OPERATING INSTRUCTIONS

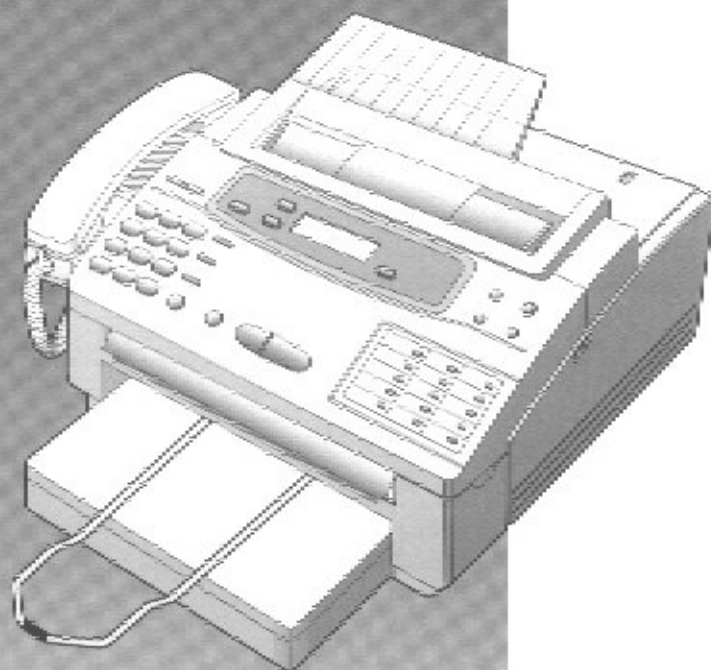

Contents

- Chapt 1. Installation and Connection*
- Chapt 2. Initial Preparation*
- Chapt 3. Making and Answering Voice Calls*
- Chapt 4. Transmitting and Receiving Fax Calls*
- Chapt 5. Operating the Answering Device*
- Chapt 6. Copier Function*
- Chapt 7. Automatic Dialing*
- Chapt 8. Advanced Operations*

Please read these Operating Instructions before using the unit and save for future reference.

**FOR OPERATION ASSISTANCE,
CALL 1-800-HELP-FAX**

Thank you for purchasing the Panasonic Telephone Answering System with Facsimile.

Things you should keep records of

Attach your sales receipt here

For your future reference

Date of purchase _____ Serial No. _____
(found on the rear of the unit)





Dealer's name and address _____

Dealer's telephone number _____

Caution:

- The telephone Consumer Protection Act of 1991 requires to clearly state the following information in the margin on the top or bottom of at least the first page of the transmission when sending any message via a telephone facsimile machine.
 - Date and time of transmission;
 - Identification of the business or other entity, or other individual sending the message;
 - Telephone number of the sending machine, business, other entity or individual.
 To program this information into your unit, you must complete the steps on pages 12 to 14.
- Note that the images of copied or received documents will remain on the used film. When disposing of the used film, use discretion.
- Do not rub the printed side or use an eraser on the printed side, as it may smear.

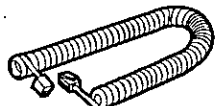
Included accessories (To order, call toll free 1-800-332-5368.)

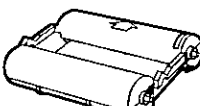
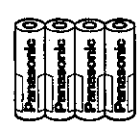
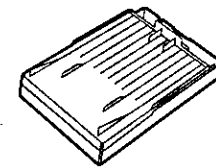
Power cord . . . 1 pc.  PQJA200Z (p. 9)	Telephone line cord 1 pc.  PQJA59V (p. 9)	Handset 1 pc.  PQJXD0105Z (p. 9)	Handset cord . . . 1 pc.  PQJA212M (p. 9)	Document feeder tray 1 pc.  PQKS10011Z (p. 8)
Document stacker 1 pc.  PQZSF1000M (p. 8)	Film cartridge 1 pc.  (pp. 4, 75) — The included film is 30 meters.	AA (R6, UM-3) size battery 4 pcs.  (p. 5)	Paper cassette 1 pc.  PQZE2F1000M (Cover) PQZE1F1000M (Tray) (p. 6)	

- If any items are missing, check with place of purchase.
- The part numbers listed above are subject to change without notice.
- Save the original carton and packaging.

Table of Contents

1. Installation and Connection

Installing the film cartridge	4
Installing the batteries	5
Installing the paper cassette	6
Installing the document stacker	8
Installing the document feeder tray	8
Connections	9
Location of controls	10

2. Initial Preparation

Setting the date and time	12
Setting your logo	12
How to enter characters and symbols	13
Setting your facsimile telephone number	14
Adjusting volumes	14
Recording a common greeting message	15
Selecting the receive mode	16

3. Making and Answering Voice Calls

Making voice calls	17
Answering voice calls	17

4. Transmitting and Receiving Fax Calls

Transmitting documents	18
Manual reception	20
Automatic reception	20

5. Operating the Answering Device

Setup of voice message and document reception	22
Listening to messages in common memory	23
Erasing recorded messages	24
Recording a memo message	24
Recording a telephone conversation	25

6. Copier Function

Making a copy	26
---------------	----

7. Automatic Dialing

Storing Tel/Fax numbers	27
Making voice calls using automatic dialing	28
Transmitting documents using automatic dialing	28
Electronic telephone directory	29

8. Advanced Operations

Facsimile

Voice contact	30
Polling	31
Delayed transmission	32
Reserving transmission during fax reception	33

Printing a cover page	33
Remote fax receiving using an extension	34
Junk mail prohibitor	35
Receiving with distinctive ring service	36

Answering device

Voice mailbox	37
Remote operation from a touch tone phone	41
Summary of remote operations	41
Programming the remote ANS ID	42
Listening to messages in common memory	42
Listening to messages in a mailbox	43
During playback	43
Erasing messages from memory	44
Other remote operations	44

Special settings

Logo print position	46
Overseas transmission mode	46
Copy reduction mode	47
Receiving reduction mode	48
Film/Paper save reception	49
Extension copy	50
Pager alert for fax reception	51
Setting the caller's recording time	52
Message alert	52
Recording time alert	53
Mailbox alert	53
Pager alert for incoming messages	54
Display contrast	55
Resetting the advanced features	55

Others

TONE, FLASH and PAUSE buttons	56
Printing reports and lists	57
Summary of user programmable features	60

9. Troubleshooting and Routine Care

Error messages on the display	61
Before requesting help	62
Clearing a recording paper jam	64
Clearing a document jam	66
Cleaning the unit	67
Replacing the film or film cartridge	68

10. General Information

Important safety instructions	70
FCC information	72
Limited warranty	73
Service center directory	74
Accessory order information	75
Specifications	75
Information for users	76
Fax Correspondence	77
Speed dialer list	79
Remote control card	81
Index	83

1. Installation and Connection

Installing the film cartridge

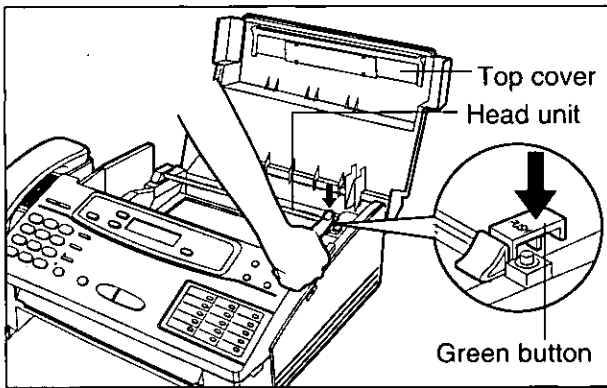

- 1 Open the top cover.
- 2 Press the green button on the right marked "PUSH" and lift up the head unit.

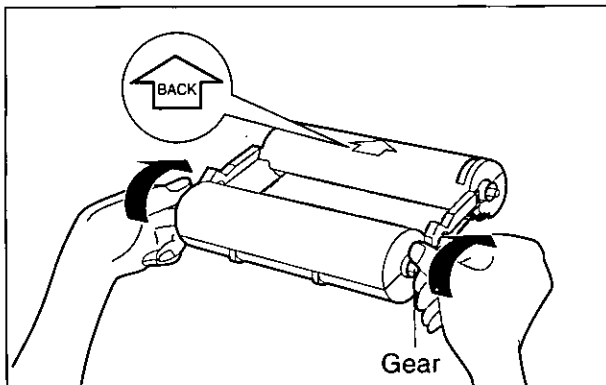

- 3 Place the cartridge with the "BACK" indicator facing up and tighten the film by winding the gears if there is slack.

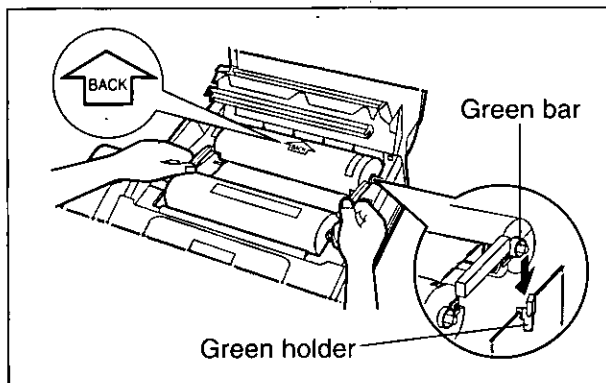
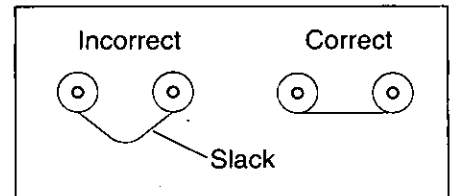

- 4 Place the "BACK" side of the cartridge into the unit, by inserting the pins on the sides of the green gears into the green holders. Then lower the front of the cartridge into place.

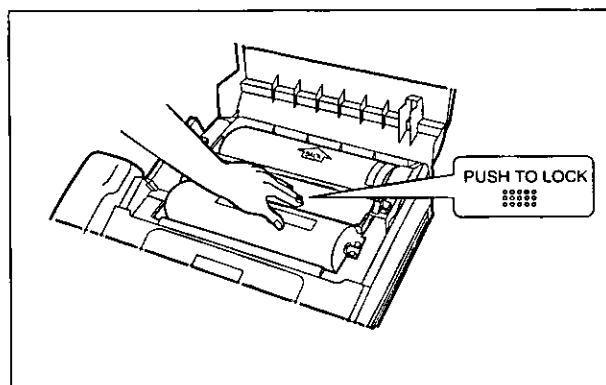

- 5 Press the head unit down firmly to lock in place.
- 6 Close the top cover securely by pushing down on both sides.

Note:

Because the length of the included film is 30 meters, it is recommended to purchase 200 meter length film for replacement soon. To order, see page 75.

Installing the batteries

The batteries are required to retain greeting and incoming voice messages in memory when the power cord is disconnected or during a power failure. Install four AA batteries (supplied) before using the unit.

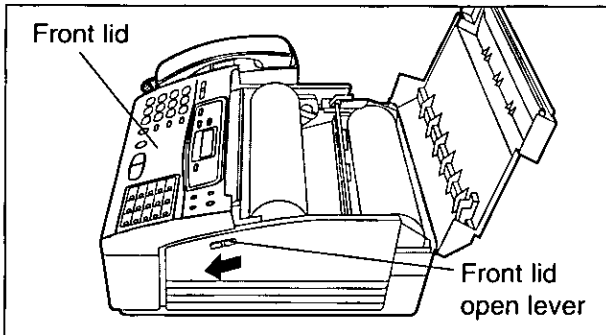

- 1 Open the top cover, then open the front lid by sliding the lever towards you.

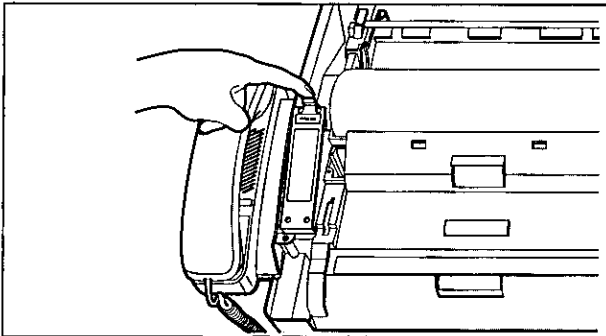

- 2 Remove the battery compartment cover by pulling the hook towards you and lifting it up.

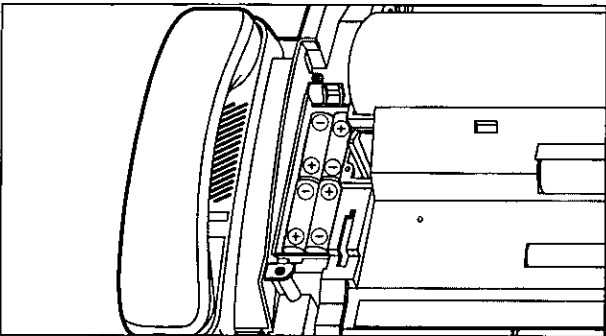

- 3 Install four batteries into the compartment using correct polarity (+, -).

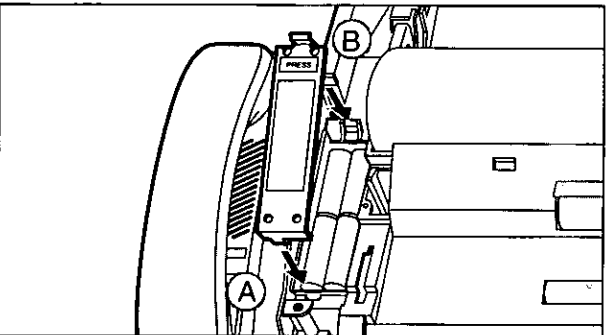

- 4 Replace the battery compartment cover by;
 - A Insert the tab of the cover into the hole.
 - B Press down the area marked "PRESS" until it clicks into place.
- 5 Close the front lid securely by pushing down on both sides, then close the top cover.

Note:

- Message retention time during a power failure is approximately 1 day with new batteries.
- Install new batteries when the display shows "BATTERY LOW".
- To avoid losing the greeting and all messages saved in memory, the power cord must remain connected when replacing batteries.
- Disconnect the telephone line cord before opening the battery compartment cover.
- Replace all the batteries once a year, or mis-operation may occur.
- For further information about batteries, see page 71.

Installing the paper cassette

You can use letter size or legal size paper. The paper cassette can hold up to 250 sheets of 75 g/m² (20 lb.) paper. Use 60 to 90 g/m² (16 to 24 lb.) paper.

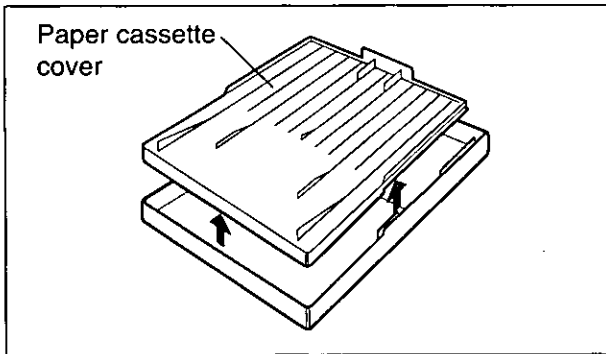

- 1 Open the paper cassette cover.
 - When removing the paper cassette from the unit, lift it up slightly (A) and pull it towards you (B).

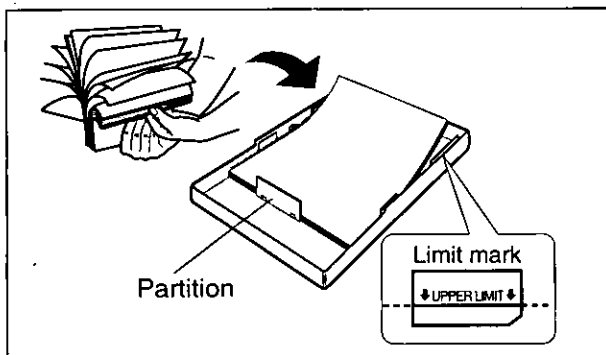
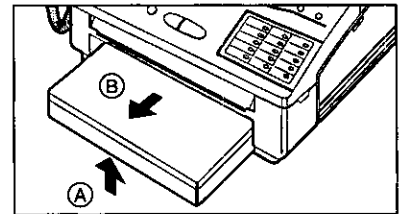

- 2 Fan the stack of paper to avoid a paper jam.

- 3 Insert the paper by aligning the paper edges with the partition.

- Most paper has instructions recommending the side to print on. Insert the paper with the print side down.
- The height of the paper should not exceed the limit mark on the paper cassette or it may cause a paper jam.
- When using legal size paper, see page 7.

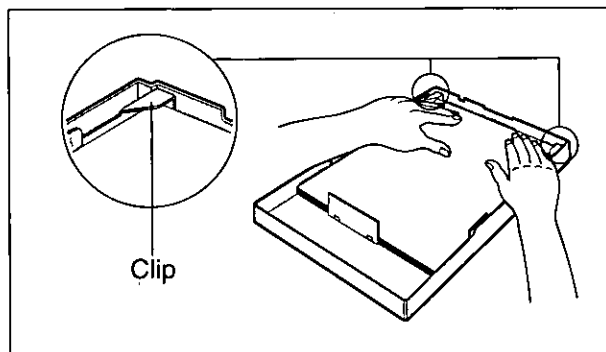

- 4 Push down the opposite edges so they are secured under the clips.

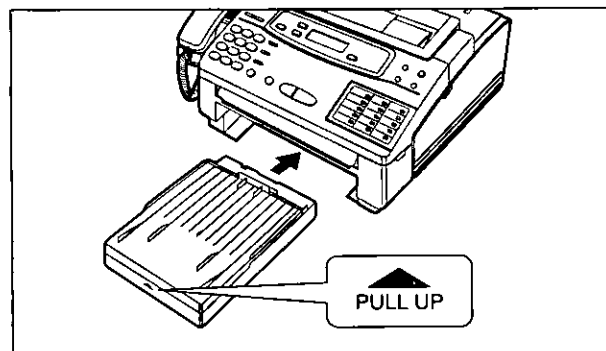
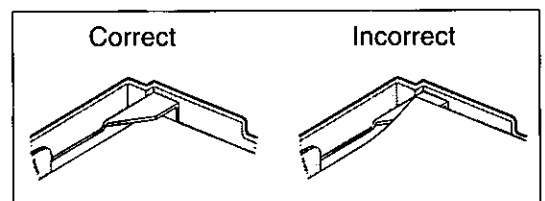

- 5 Close the paper cassette cover and insert the paper cassette into the unit until it clicks into place.

Using legal size paper

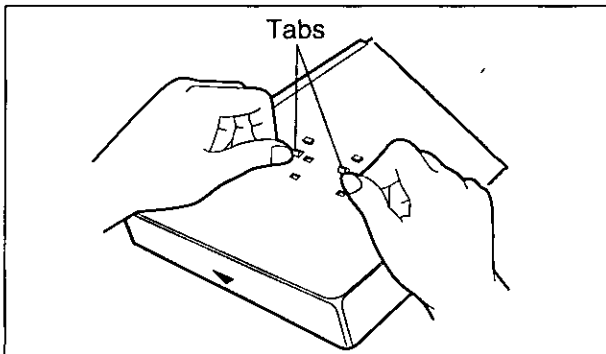

- 1 Turn over the cassette and remove the partition by pushing the lower two tabs of the partition.

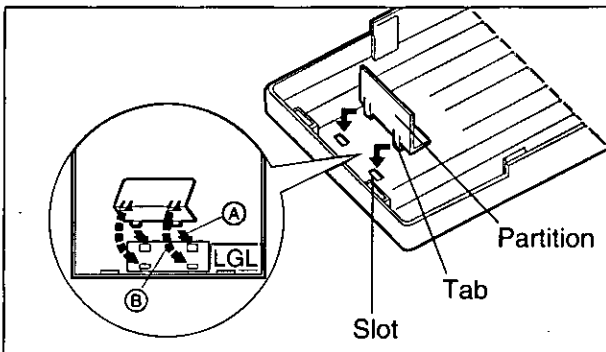

- 2 Turn over the cassette and install the removed partition by inserting the two tabs into the upper slots (marked as LGL)(A), and then the other two tabs into the lower slots (B).
- 3 Insert the paper.

Note:

- Do not insert paper of different thickness into the cassette at same time. This may cause a paper jam.
- Avoid extremely smooth or shiny paper that is highly textured. Also avoid paper that is coated, damaged or wrinkled, or paper with a cotton and/or fiber content that is over 20%.
- Avoid used paper for double-sided printing.
- Do not use paper printed with this unit for double-sided printing with other copiers or printers, or a paper jam may occur.

Installing the document stacker

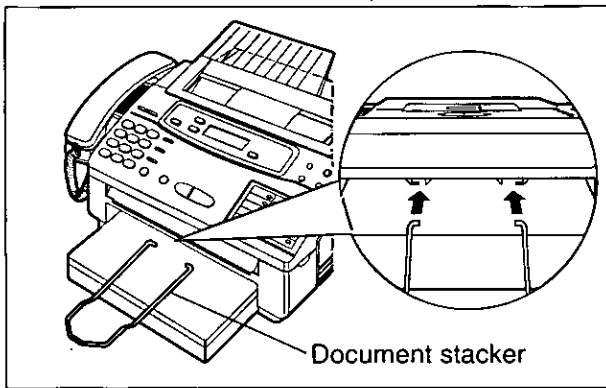

Insert the document stacker with the bent side facing up until it clicks into place.

Helpful hint:

To extend the document stacker, pull it towards you until it clicks into place.

To save space, slide the document stacker into the unit until it clicks into place.

Installing the document feeder tray

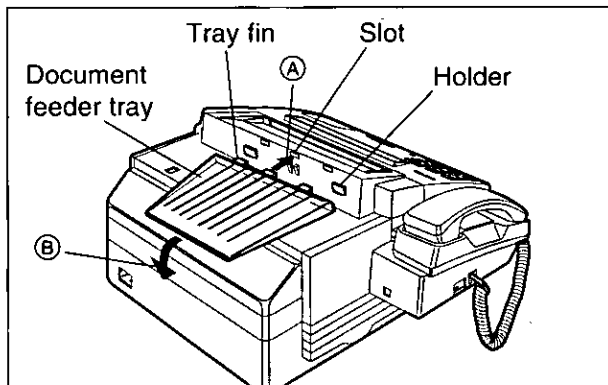

1 Insert the three tray fins into the slots of the unit (A).

2 Press down the tray to place it on the two holders (B).

Connections

1

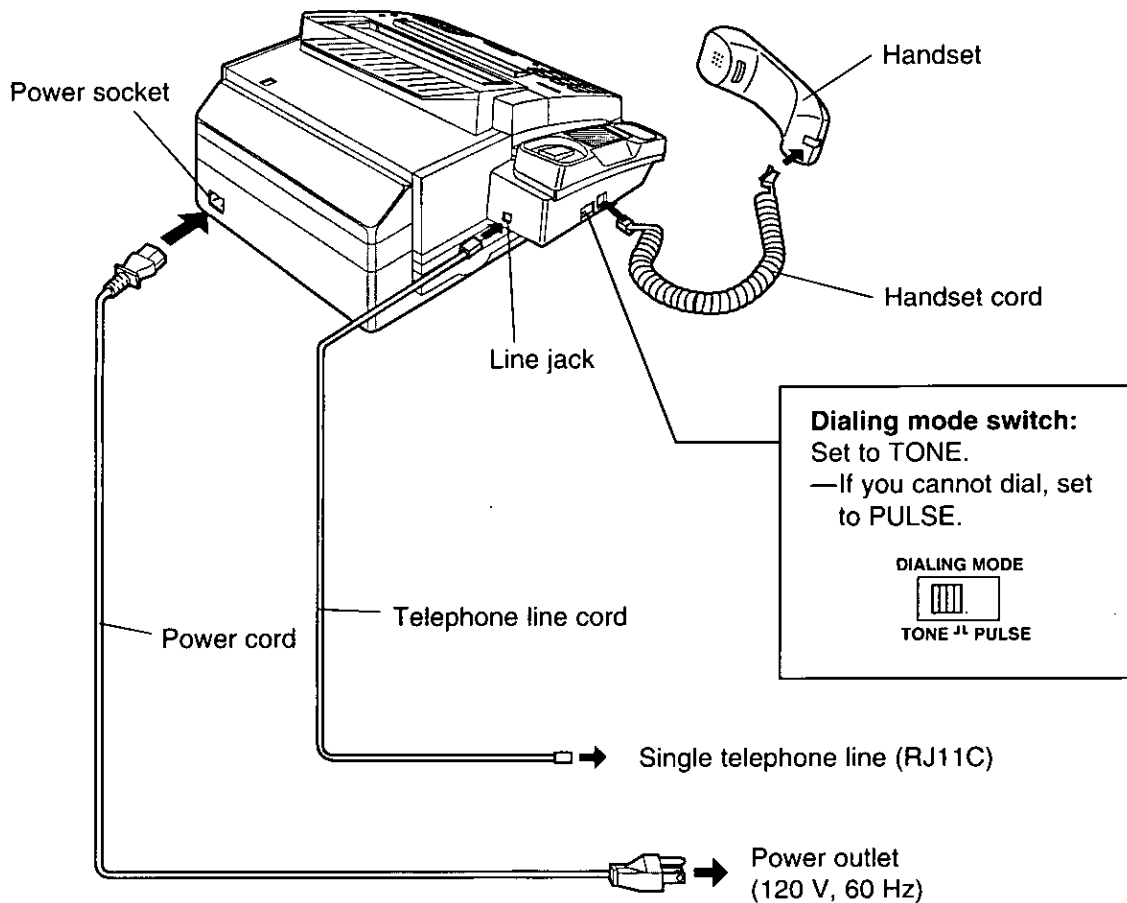

Note:

- We recommend the use of an exclusive power outlet to avoid interference from other equipment.
- When you operate this product, the power outlet should be near the product and easily accessible.
- The unit will not function during a power failure.
- For additional equipment protection, we recommend the use of a surge protector. The following types are available; TELESPIKE BLOK MODEL TSB (TRIPPE MFG. CO.), SPIKE BLOK MODEL SK6-0 (TRIPPE MFG. CO.), SUPER MAX (PANAMAX) or MP1 (ITW LINX).

Helpful hint:

If assistance is needed, press the HELP button. The unit will print a quick reference.

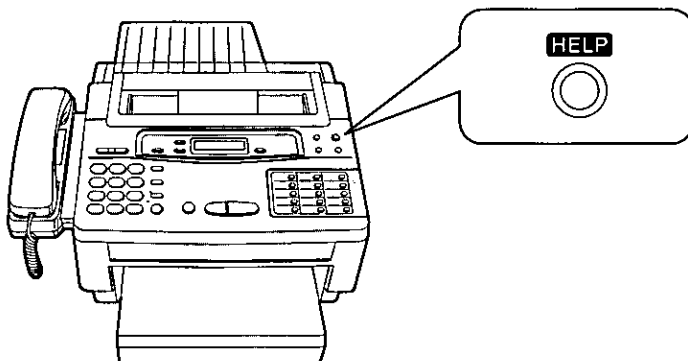

Location of controls

Front view

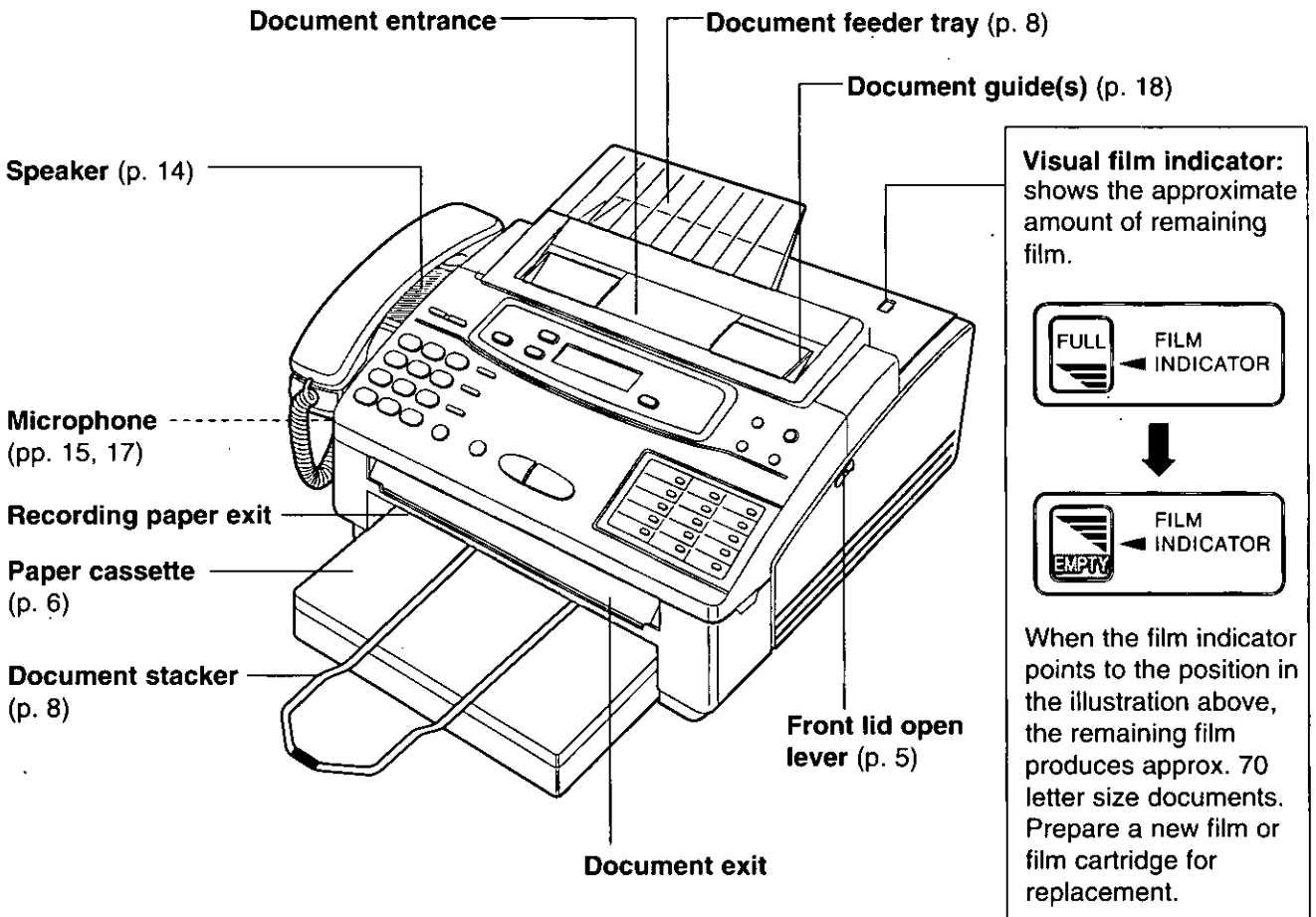

Note:

The visual film indicator will show "FULL" when a new 200 meter film is installed. When the included film cartridge (30 meter roll film) is installed, the indicator will not show "FULL".

Control panel

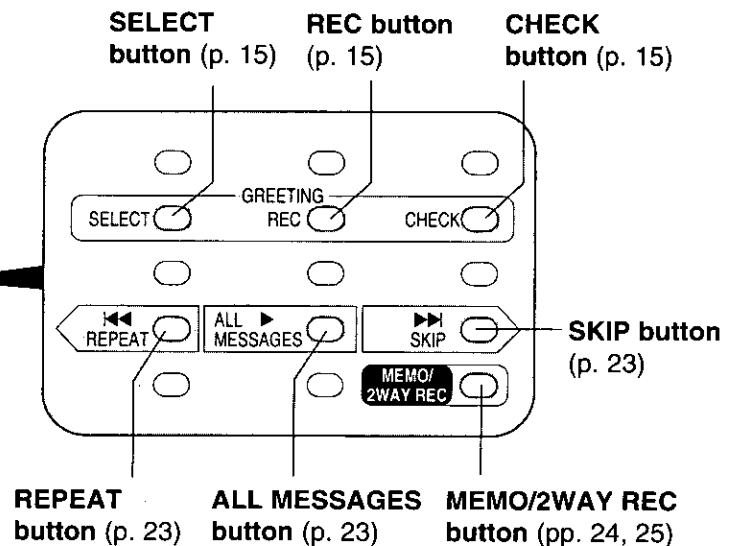
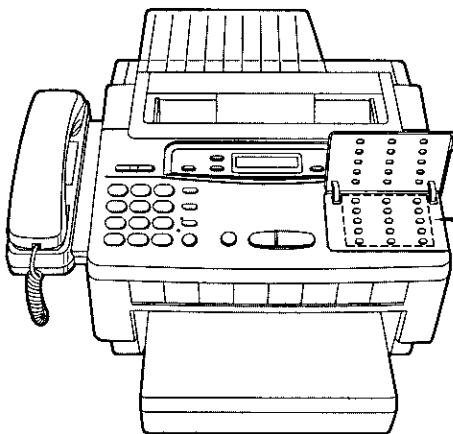
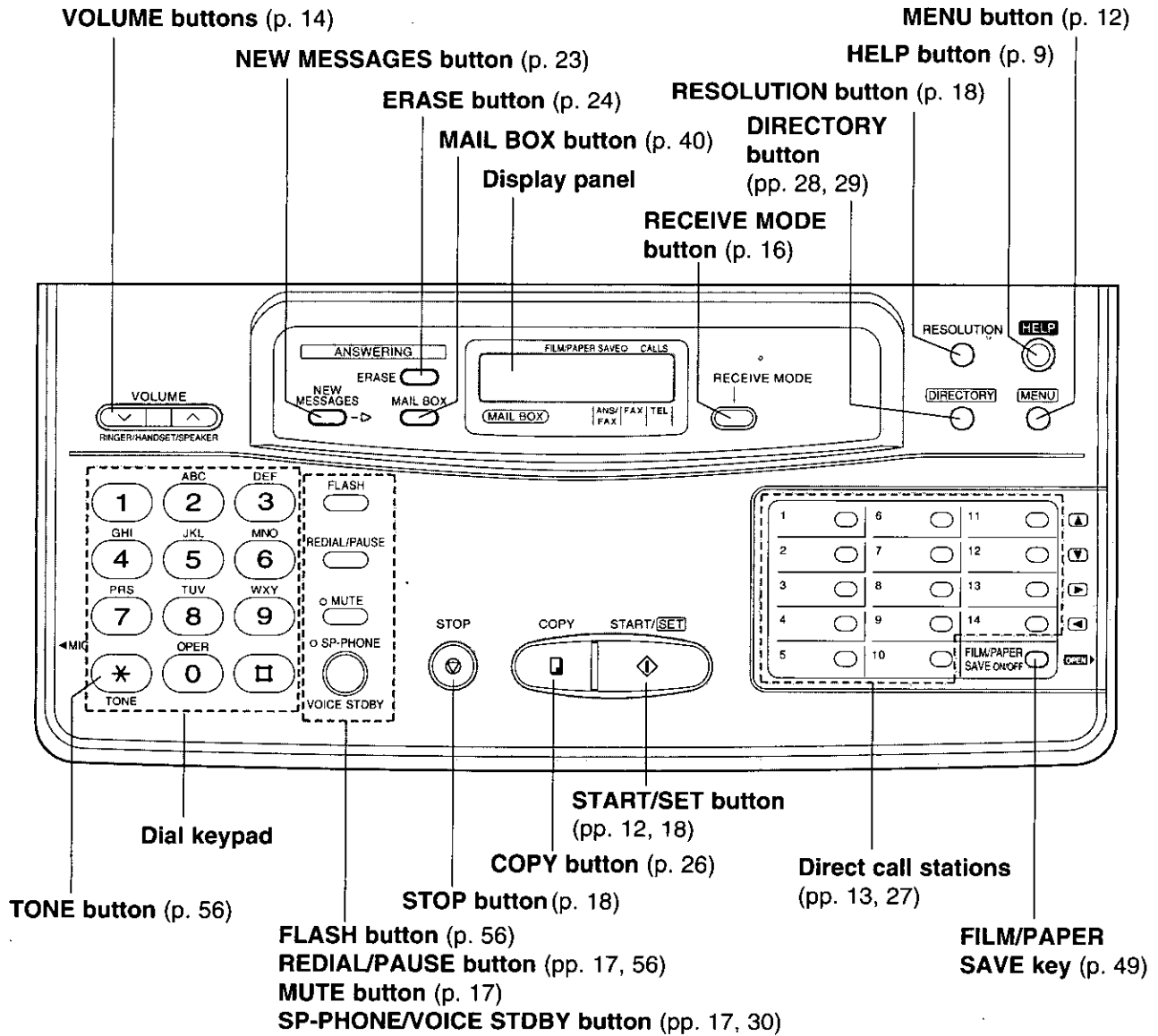

2. Initial Preparation

Before using your unit, program the following:

- Current date and time
- Your logo
- Your facsimile telephone number

This information will be printed on the top of each page transmitted from your unit.

Setting the date and time

- 1 Press **MENU**.
SYSTEM SET UP
- 2 Press **#**, then **0 1**.
SET DATE & TIME
- 3 Press **START/SET**.
- 4 Enter the correct month/day/year/hour/minute by selecting each 2 digits.
Then press ***** for AM or press **#** for PM.
Example: Aug. 10 1995, 3:00PM
Press **0 8 1 0 9 5 0 3 0 0**,
then press **#** for PM.
- 5 Press **START/SET**.
- 6 Press **MENU**.

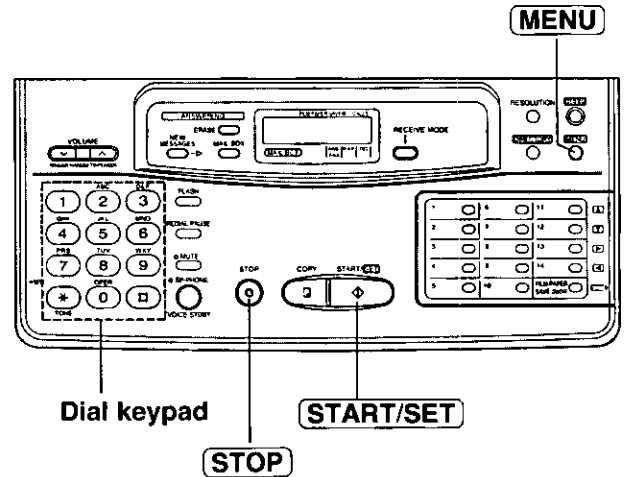

Note:

- When you make a mistake while programming, press **STOP** then make the corrections.
- The accuracy of the clock will be approximately ± 60 seconds a month.

Setting your logo

Usually the logo is a company, division or personal name in an abbreviated form.

- 1 Press **MENU**.
SYSTEM SET UP
- 2 Press **#**, then **0 2**.
YOUR LOGO
- 3 Press **START/SET**.
LOGO=
- 4 Enter your logo up to 30 characters.
(The preset logo will be cleared.)
• Refer to the instructions on page 13.
- 5 Press **START/SET**.
- 6 Press **MENU**.

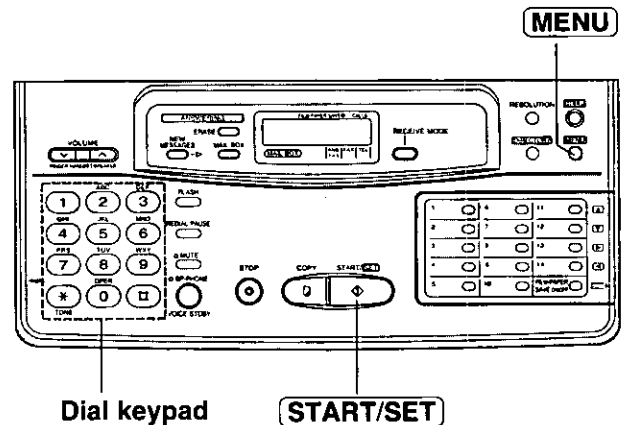

How to enter characters and symbols

The dial keypad and the direct call stations can be used as character input keys and command keys. Pressing 0–9 and direct call station 1 will alternately select a character as shown below.

Keys	Number of times												
	1	2	3	4	5	6	7	8	9	10	11	12	13
①	1	[]	{	}	+	-	/	=	,	.	_	'
②	A	B	C	a	b	c	2						
③	D	E	F	d	e	f	3						
④	G	H	I	g	h	i	4						
⑤	J	K	L	j	k	l	5						
⑥	M	N	O	m	n	o	6						
⑦	P	Q	R	S	p	q	r	s	7				
⑧	T	U	V	t	u	v	8						
⑨	W	X	Y	Z	w	x	y	z	9				
⑩	0	()	<	>	!	"	#	\$	%	&	¥	
⑪	:	;	?		*	@	^	'	→				
⑫	INSERT key (Used to insert one character or one space.)												
⑬	SPACE key (Used to replace one character with a space.)												
⑭	DELETE key (Used to delete one character.)												
⑮	▶ key (Used to move the cursor to the right.)												
⑯	◀ key (Used to move the cursor to the left.)												

For example, when entering "Mike" as your logo:

- 1 Press ⑥, then press direct call station ⑬.

LOGO=M

- 2 Press ④ six times, then press direct call station ⑬.

LOGO=Mi

- 3 Press ⑤ five times, then press direct call station ⑬.

LOGO=Mik

- 4 Press ③ five times.

LOGO=Mike

Note:

- If you make a mistake while programming, use direct call stations ⑬ and ⑭ to move the cursor to the incorrect character, then make the correction.
- The layout of the direct call station keys is printed on the reverse side of the directory card. Remove the directory card cover with a pencil or similar object and turn the directory card over.

Setting your facsimile telephone number

- 1 Press **MENU**.

SYSTEM SET UP
- 2 Press **#**, then **0 3**.

YOUR TEL NO.
- 3 Press **START/SET**.

NO. =
- 4 Enter your facsimile telephone number up to 20 digits.
 • **#** button inserts a space and ***** button a "+".
- 5 Press **START/SET**.
- 6 Press **MENU**.

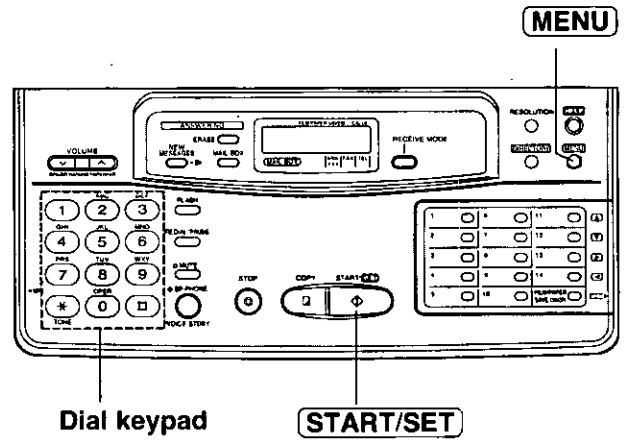

Note:

Logo, telephone number, date, time and page number will be printed outside of the document you send. To change the print position, see page 46.

Adjusting volumes

- **Ringer volume:** 3 levels (high/low/off) are available. Press **VOLUME** (v/∧) while the unit is in an idle status.

To turn the ringer off:

1. Press v repeatedly.
 • The following messages will be shown alternately.

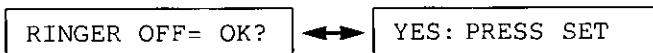

2. Press **START/SET**.

While the ringer volume is set to off:

The display will show the following message and the unit will not ring when receiving a call.

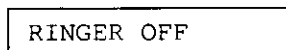

- **Handset volume:** 3 levels (high/middle/low) are available. Press **VOLUME** (v/∧) when using the handset.
- **Speaker volume:** 8 levels (high to low) are available. Press **VOLUME** (v/∧) when using the speakerphone.
- **Answering device volume:** 9 levels (high to off) are available. Press **VOLUME** (v/∧) when listening to the recorded messages.

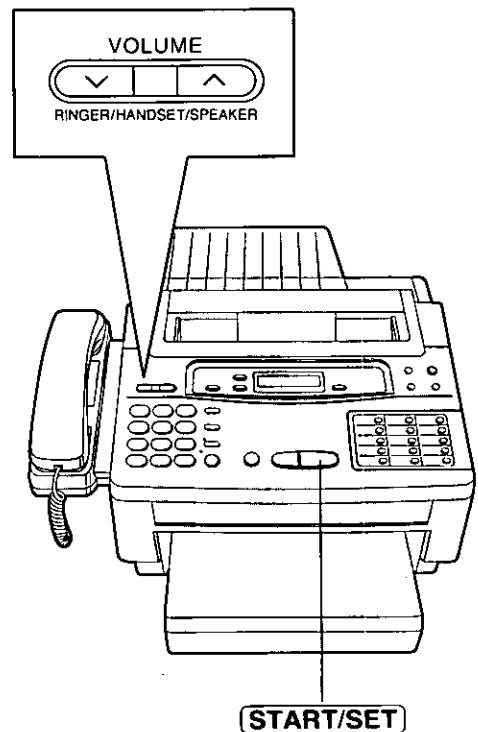

Recording a common greeting message

Record a common greeting message before using the unit as an answering device and facsimile.

The greeting message tells the caller that you are unable to answer, and allows the caller to leave a voice message or send a fax message.

The recording time is limited to 16 seconds. Record the greeting message **within 12 seconds** for optimum performance.

- 1 Open the station key panel.
- 2 Press **SELECT**.

ANS-GREETING
- 3 Press **REC**.
 - A long beep will sound.
- 4 After the long beep, speak clearly 20 cm (8 inches) away from microphone.
 - The display will show the elapsed recording time.

ANS REC. 02s
- 5 When finished, press **STOP**.
 - The unit will repeat your message for confirmation. Adjust the volume to a suitable level by pressing **VOLUME**.

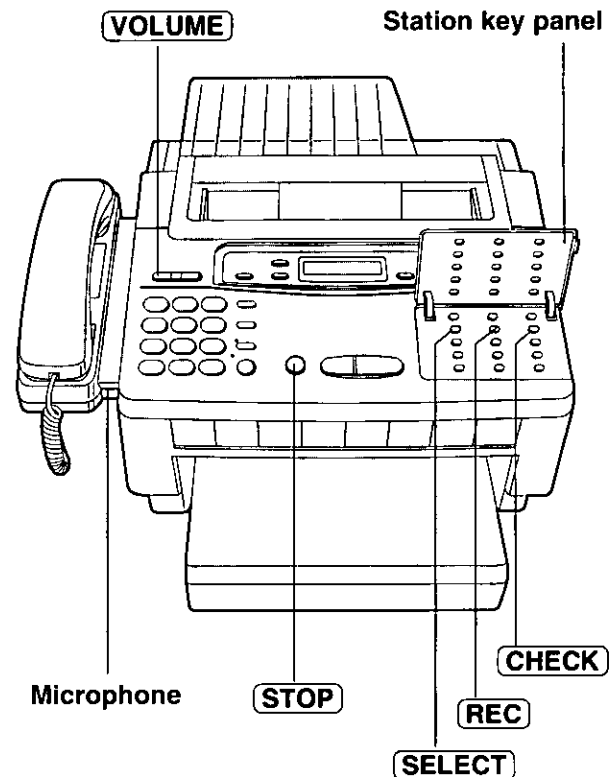

Note:

If you make a mistake while recording, repeat from step 2.

Suggested message

"This is (your name, business and/or telephone number). We are unable to answer right now. To send a fax, start transmission. To leave a message, speak after a long beep. Thank you."

To check your greeting message

1. Press **SELECT**.

ANS-GREETING
2. Press **CHECK**.

To erase the recorded greeting message

1. Press **SELECT**.

ANS-GREETING
2. Press **REC**.
3. Press **STOP** immediately after a long beep.

Selecting the receive mode

This unit combines the function of telephone, facsimile and answering system. To perform these functions, this unit has three types of receive modes; ANS/FAX, FAX and TEL.

Regardless of the mode that you select, you can always place calls and send faxes. The descriptions below will help you understand how the unit can work for you.

ANS/FAX mode:

This mode can be used when you wish the unit to record voice messages and/or receive fax messages. When a call is received, the unit will play the common greeting message. If a voice call is detected, the answering system will begin recording, then caller can leave a voice message. If a fax call is detected, the unit will switch to the fax and receive fax documents.

FAX mode:

We recommend that you select this mode when you will be using the unit solely as a fax machine. The unit will automatically answer all calls and generate fax tones to the callers. Callers will hear fax tones and will only be able to transmit faxes.

TEL mode:

This mode can be used when you wish to answer all calls manually. The unit will not automatically answer fax and voice calls. If you wish to answer a fax call, you can start reception by pressing the START/SET button. If no one answers an incoming call by 15 rings, the receive mode will switch to the ANS/FAX mode automatically.

Select the desired mode by pressing **RECEIVE MODE** repeatedly. The arrow mark in the display shows your selection.

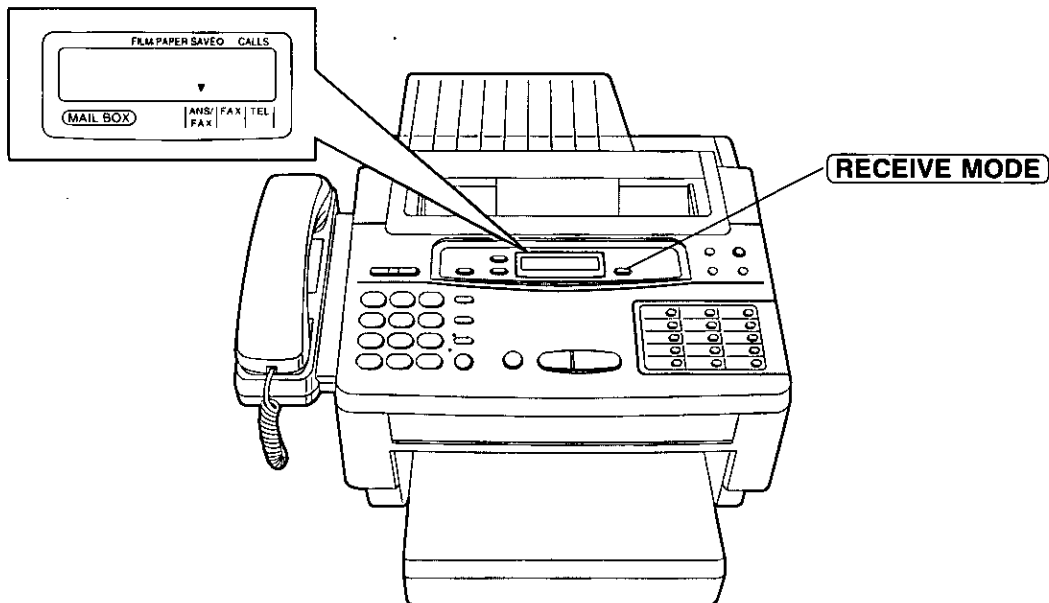

3. Making and Answering Voice Calls

Making voice calls

- 1 Press **SP-PHONE** or lift the handset.
- 2 Dial a phone number.
 - If you misdial, hang up and dial again.
- 3 When the other party answers, speak into the microphone or handset.
- 4 When finished, press **SP-PHONE** again or replace the handset.

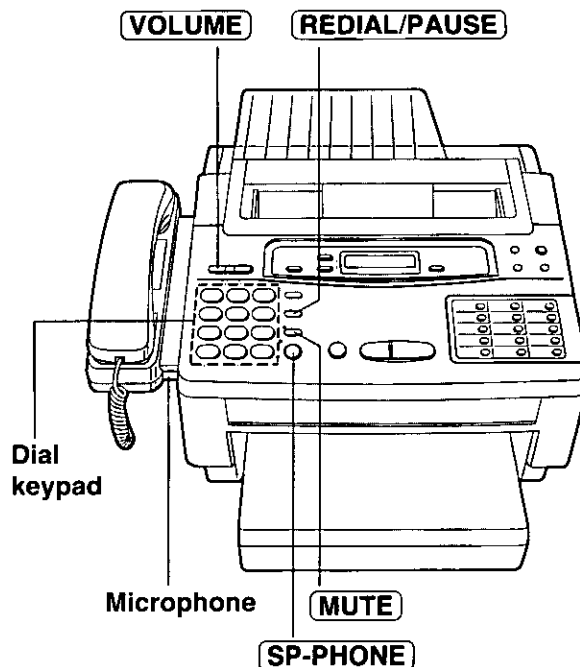

To redial the last number dialed

1. Press **SP-PHONE** or lift the handset.
2. Press **REDIAL/PAUSE**.
 - If the line is busy when using the speakerphone, the unit will automatically redial the number up to 14 times.

Voice muting

Using this feature, you can hear the voice of the other party, but the other party cannot hear your voice.

1. Press **MUTE** during a telephone conversation.
 - The MUTE indicator light goes on.
2. To resume the conversation, press **MUTE** again.

Hints for speakerphone operation

- Use the speakerphone in a quiet room for best performance.
- If the other party has difficulty hearing you, adjust the volume using **VOLUME**.
- If you and the other party speak at the same time, parts of your conversation will be lost.
- If you wish to switch to the handset from the speakerphone, lift the handset. To switch to the speakerphone, press **SP-PHONE**.

Answering voice calls

- 1 When the unit rings, lift the handset or press **SP-PHONE**.
- 2 To hang up, replace the handset or press **SP-PHONE**.

4. Transmitting and Receiving Fax Calls

Transmitting documents

Loading documents

- 1 Insert the documents **FACE DOWN** until a beep tone is heard.
 - The unit can accept up to 15 sheets of paper at a time.
- 2 Adjust the document guides to the width of the documents.
- 3 Press **RESOLUTION** repeatedly to the desired setting.
 - The selected resolution will be shown on the display.

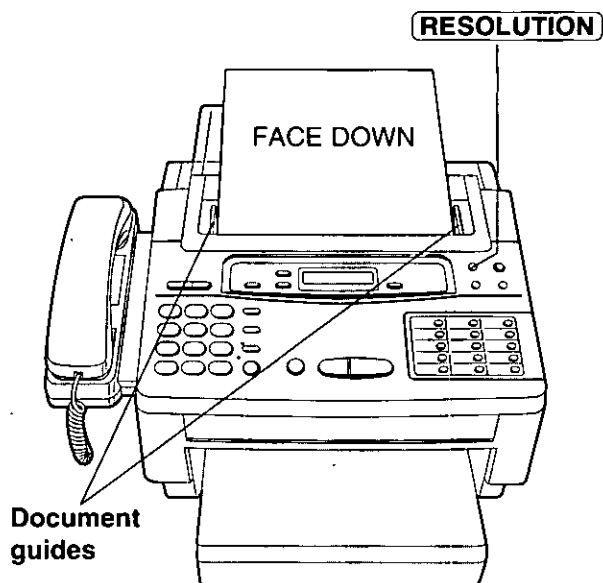

Selecting the resolution

STANDARD: Suitable for printed or typewritten originals with normal-sized characters.

FINE: Suitable for originals with small printing.

HALF TONE: Useful for originals containing photographs, shaded drawings, etc.

- Note that using the FINE or HALF TONE setting will increase transmission time.
- If the setting is changed during page feeding, it will be effective from the next sheet.

Transmitting documents manually

- 1 Insert the documents **FACE DOWN**.
- 2 Press **SP-PHONE** or lift the handset.
- 3 Dial a phone number.
 - If you misdial, hang up and dial again.
- 4 When a fax tone is heard, press **START/SET**.
- 5 Replace the handset if using it.

To stop transmission halfway

Press **STOP**.

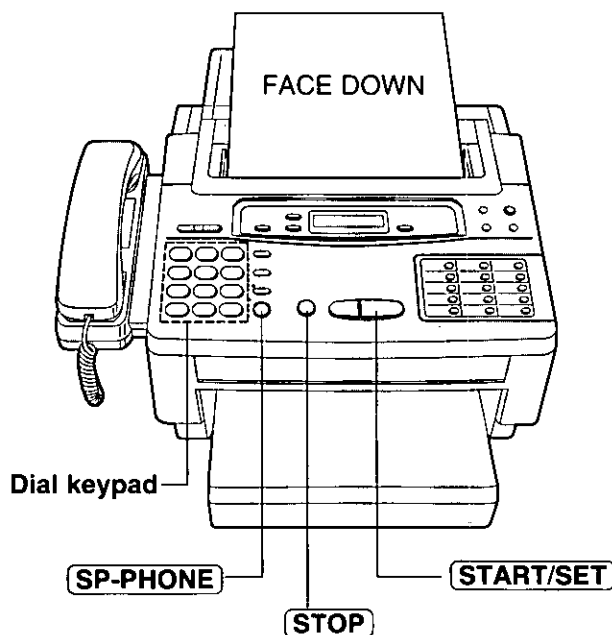

Transmitting documents with fewer procedure

- 1 Insert the documents **FACE DOWN**.
- 2 Dial a phone number.
 - If you misdial, press **STOP** and dial again.
- 3 Press **START/SET**.
 - The unit will start to dial and transmit the documents.

Note:

If there is no answer or the line is busy, the unit will automatically redial the number up to 5 times. To cancel redialing, press **STOP**.

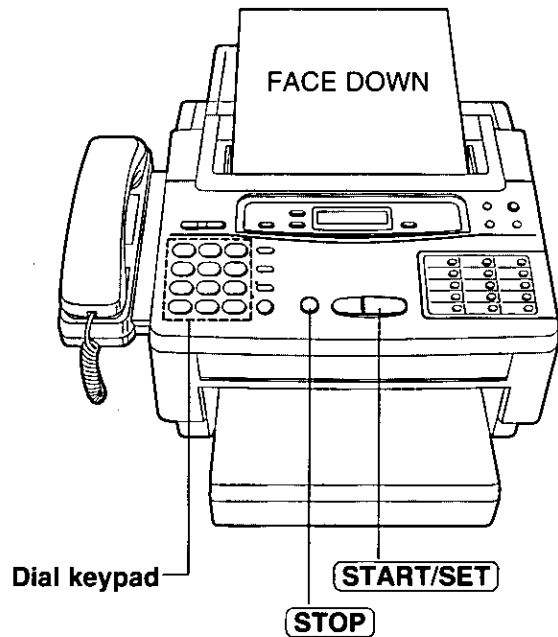

To send 16 or more sheets at a time

Insert the first 15 sheets of the documents. Add the extra sheets (up to 15) before the last sheet is fed into the unit.

Documents you can send

Minimum size

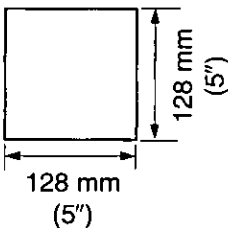

Maximum size

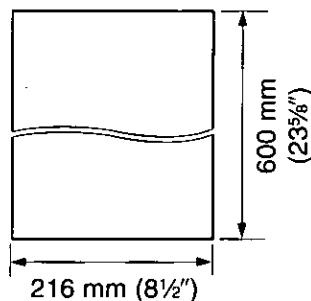

Effective scanning area

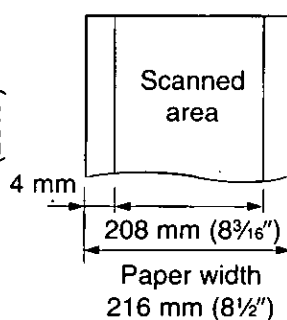

Document weight

Single sheet:
45 to 90 g/m² (12 to 24 lb.)
Multiple sheets:
60 to 75 g/m² (16 to 20 lb.)

Note:

- Remove clips, staples or other similar fastening objects from a document.
- Check that ink, paste or correction fluid on the documents have completely dried.
- Do not feed the following types of documents into the unit. Make copies of these documents by using a copier then use these copies for fax transmission.
 - Paper with a chemically treated surface such as carbon paper or carbonless duplicating paper
 - Electrostatically charged paper
 - Heavily curled, creased or torn paper
 - Paper with a coated surface
 - Paper with faint contrast between the printing and the background
 - Paper with printing on the reverse side that can be seen through the front (e.g. newspaper)

Manual reception

- 1 When the unit rings, press **SP-PHONE** or lift the handset to answer the call.
- 2 When:
 - document reception is required,
 - a slow beep is heard, or
 - no sound is heard,press **START/SET**.
- 3 Replace the handset if using it.
 - The unit will start reception.

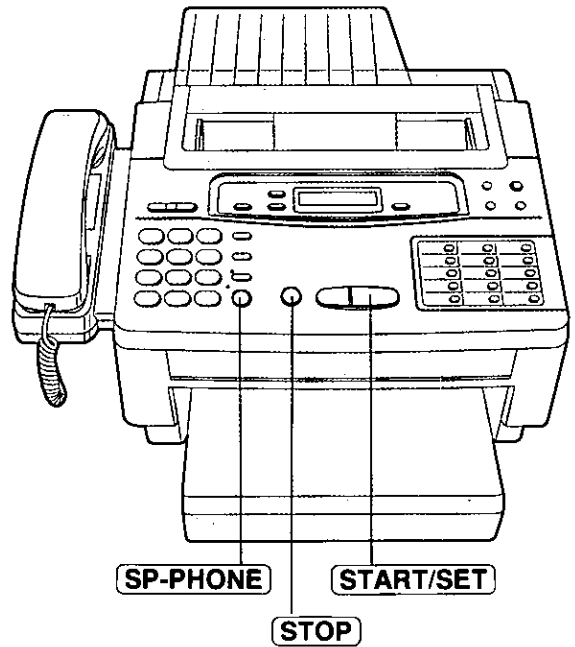

To stop reception halfway

Press **STOP**.

Note:

- When receiving an over-sized document, the unit will divide it into two or more pages when printing out.
- If an appropriate reduction rate (page 48) is set, the unit can print an over-sized document on one page.

Automatic reception

Set the RECEIVE MODE to the ANS/FAX or FAX mode.

For further details, see page 16.

Helpful hint:



- The unit will answer the call after one ring. The number of rings to answer the call can be changed. See page 21.
 - If you wish to be able to answer a call before the unit does, increase the number of rings.
 - If you find difficulty in receiving faxes from machines that have an automatic transmission feature, decrease the number of rings.
 - If you subscribe to a caller ID/call display service, set the number of rings to more than 2.
- Transmit the leaflet on page 77 to several of your associates. This way, you can tell them the procedure for transmitting documents and/or recording voice-messages.

Caution:

Do not let more than 100 sheets of paper accumulate at one time on the paper cassette. This may cause a paper jam.

Setting the ANS/FAX mode ring count

You can choose from 1, 2, 3, 4, toll saver and ringer off.

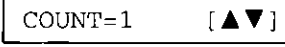
- 1 Press **MENU**.

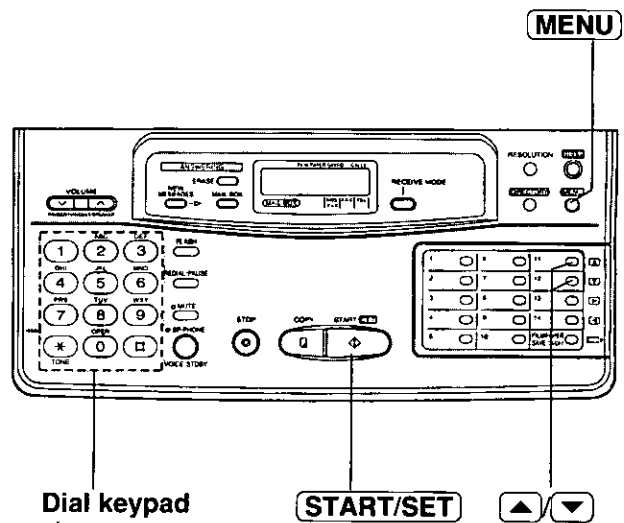
- 2 Press **#**, then press **08**.

- 3 Press **START/SET**.

- 4 Press **▲** or **▼** to select the desired number of rings.
- 5 Press **START/SET**.
- 6 Press **MENU**.



Toll saver:

When you call the unit from a remote location, the number of rings will tell you if there are any new voice messages or not.

If the unit answers on the first ring, there is at least one newly recorded message.

If the unit answers on the third ring, there are no newly recorded messages.

Hang up immediately when you hear the second ring. This will save you the toll charge for the call.

Setting the FAX mode ring count

You can choose from 1 to 4 rings.

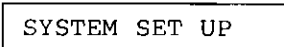
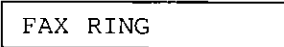
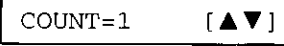
- 1 Press **MENU**.

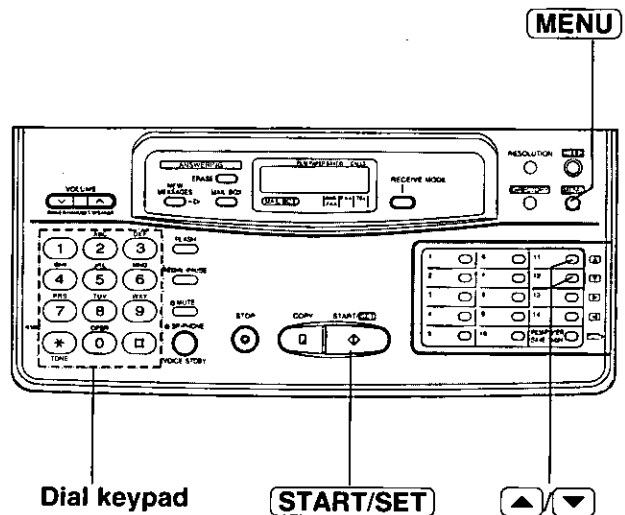
- 2 Press **#**, then press **07**.

- 3 Press **START/SET**.

- 4 Press **▲** or **▼** to select the desired number of rings.
- 5 Press **START/SET**.
- 6 Press **MENU**.



5. Operating the Answering Device

Setup of voice message and document reception **=====**

To record voice message and receive fax document

Set the unit to the ANS/FAX mode by pressing **RECEIVE MODE**.

Monitoring incoming calls

While an incoming call is being recorded, you can monitor it through the speaker. Adjust the volume with the VOLUME buttons.

To answer the call while monitoring, press **SP-PHONE** or lift the handset. The unit will stop recording.

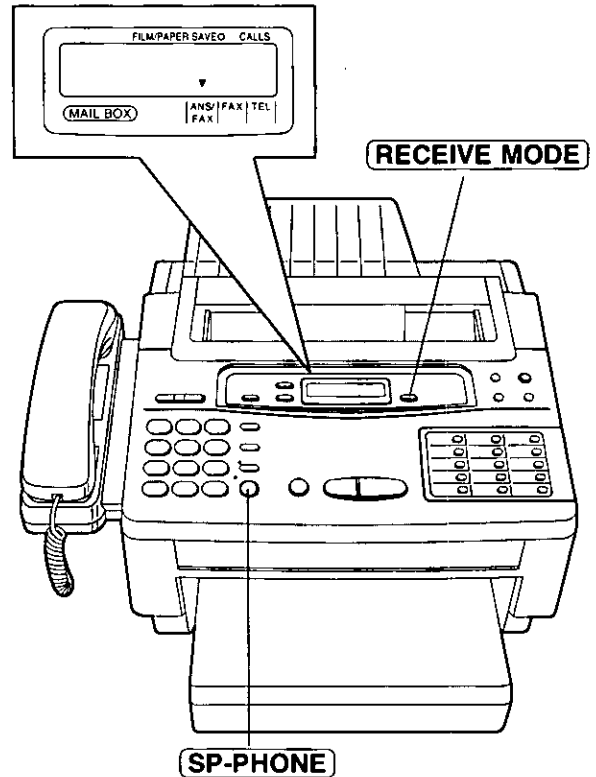

Total recording time

The unit can save a total of about 15 minutes of voice recordings in common memory and three mailbox memories.

- If the incoming messages are noisy, the recording time might be less than 15 minutes.

Recording time for each incoming message:

The recording time for each incoming message can be set to either "unlimited" (preset setting) or "1 minute". To change the recording time, see page 52.

To confirm the time remaining for incoming message:

Select the ANS/FAX mode by pressing **RECEIVE MODE** or open the station key panel.

The display will show the remaining time for about 2 seconds.

TIME LEFT=12MIN

- When the remaining time is little, erase useless messages from memory (see page 24).
- When the remaining time becomes less than 60 seconds, the unit will alert the user with a slow beep if a recording time alert feature is set to on (page 53).

Listening to messages in common memory

When the unit receives voice messages,
 —the NEW MESSAGES indicator will flash.
 —a slow beep will sound if message alert (page 52) is set to ON.

To listen to new messages

Press **NEW MESSAGES**.

- The unit will play back the new recorded messages.
- At the end of the last message, 3 beeps will sound.

To listen to all the recorded messages

1 Open the station key panel.

2 Press **ALL MESSAGES**.

- The unit will play back all the recorded messages.

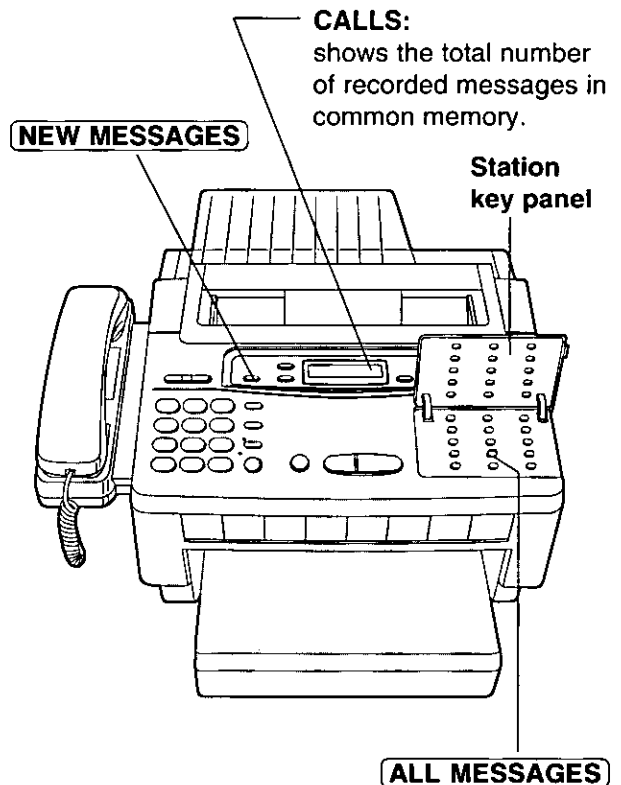

Day and time display

During playback, the display will show the recorded day and time, along with the recorded order of the message.

SUN 12:00AM 01

Saving message

The unit will save the incoming messages automatically, if the user does not erase them.

Functions during playback

To repeat a message

Press **REPEAT** to play back the previous message.

To skip a message

Press **SKIP** to play back the next message.

To stop the operation

Press **STOP** to stop playback or other operation.

- If you wish to resume playback, press the NEW MESSAGES or ALL MESSAGES button within 1 minute after pressing the STOP button.

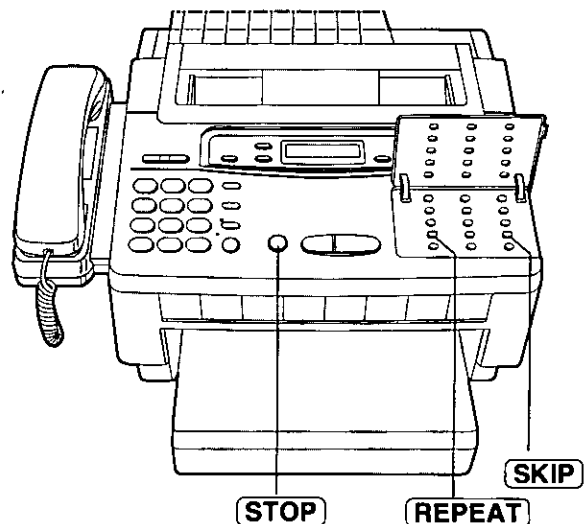

Erasing recorded messages

To erase specific messages from memory

Press **ERASE** while the message you want to erase is playing.

To erase all messages in common memory

1 Press **ERASE** after listening to all of the messages.

ICM ERASE OK?

2 Press **START/SET**.

ERASE COMPLETED

- If this feature is not required, press **ERASE** or **STOP** instead of **START/SET**.

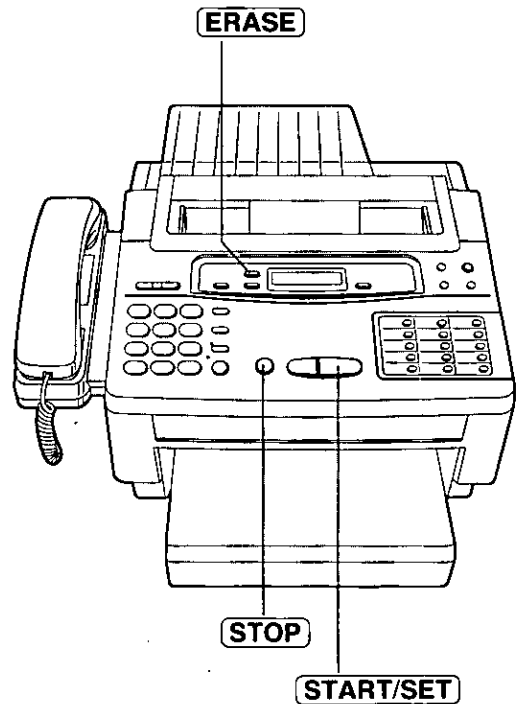

Recording a memo message

If the user is going out and wants to leave a private message for someone, they can record a voice memo in the unit. This can be played back later either directly or remotely, like other messages.

1 Open the station key panel.

2 Press **MEMO/2WAY REC**.

3 Immediately after the beep, speak clearly towards the microphone.

4 When finished, press **MEMO/2WAY REC** again or **STOP**.

Note:

- When memory becomes full while recording, the unit will stop recording automatically and 6 beeps will be heard. Erase some or all messages.
- This feature can also be used with the mailbox feature. To record in a specific mailbox, you must first select the mailbox by pressing **MAIL BOX**.

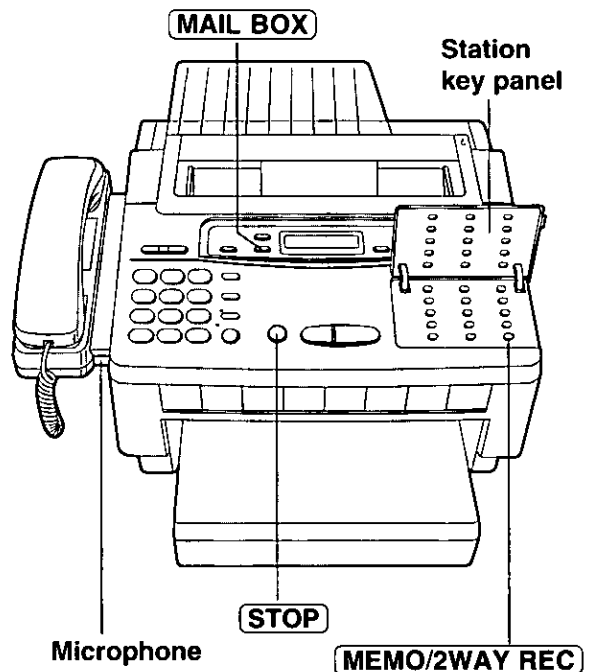

Recording a telephone conversation

The user may record a telephone conversation.

- 1 During the conversation, open the station key panel and press **MEMO/2WAY REC**.
- 2 To stop recording,
Press **MEMO/2WAY REC** again or **STOP**.
or
Hang up after the conversation.

Note:

- This feature can also be used with the mailbox feature. To record in a specific mailbox, you must first select the mailbox by pressing **MAIL BOX**.
- There may be imposed regulations in your area (state) concerning the manner in which 2-way telephone conversations may be recorded. So you should inform the other party that the conversation is being recorded. Consult your local telephone company for further information.

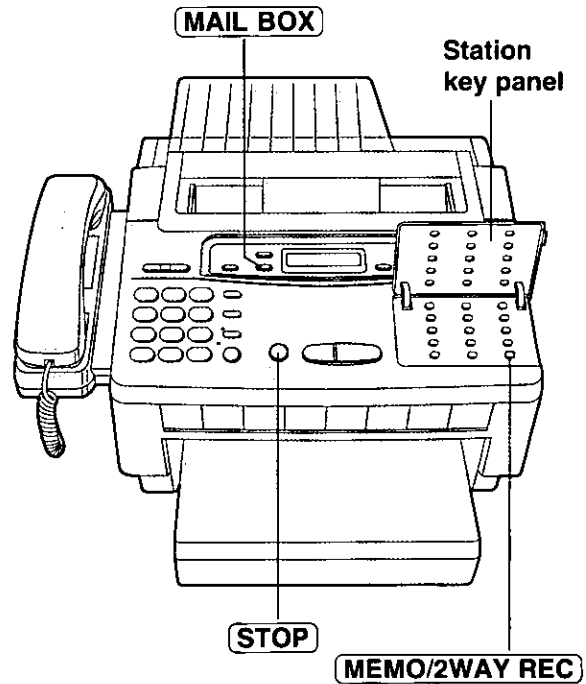

6. Copier Function

Making a copy

- 1 Insert the documents FACE DOWN.
 - The unit can make a copy of up to 15 sheets of paper at a time.
- 2 Press **COPY**.
 - The unit will start copying.

To stop copying halfway

- Press **STOP**.
- The unit will stop copying and eject the documents.

Note:

- Any transmittable document can be copied (see page 19).
- When copying, the unit will automatically select FINE resolution.
- You can make or receive a voice call while making a copy.

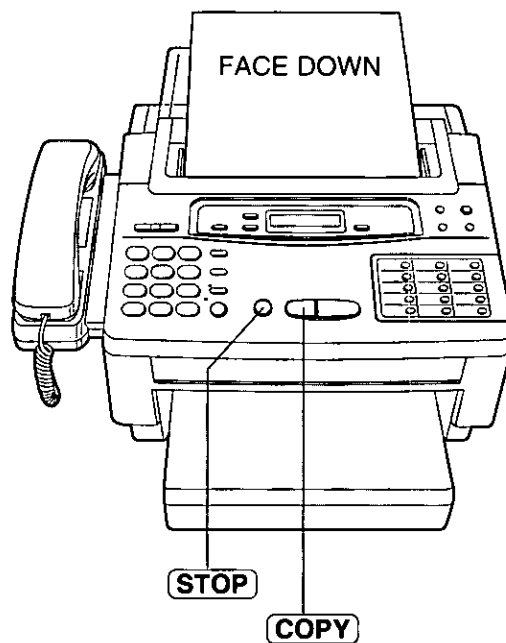

7. Automatic Dialing

The unit's memory allows you to use both one-touch dialing and speed dialing for rapid access to your most frequently dialed numbers.

One-touch dialing: The unit is equipped with 14 direct call station keys.

Speed dialing: The unit is equipped with 60 additional dialing stations. These stations are assigned to 2-digit numbers (00–59).

Storing Tel/Fax numbers

1 Press **MENU** until the following message is displayed.

STORE TEL NO.

2 **For one-touch dialing:**
Press one of the direct call station keys.

For speed dialing:

Press **[#]**, then press the desired 2-digit number (00–59).

3 Enter the phone number up to 30 digits in length.

•To enter a hyphen in a phone number, press **HYPHEN** (direct call station 8).

4 Press **START/SET** to store the number.

NAME=

5 Enter the station name, up to 10 characters, by following the instructions on page 13.

6 Press **START/SET** to store the station name.

•To program other stations, repeat from step 2.

7 Press **STOP** to end the program.

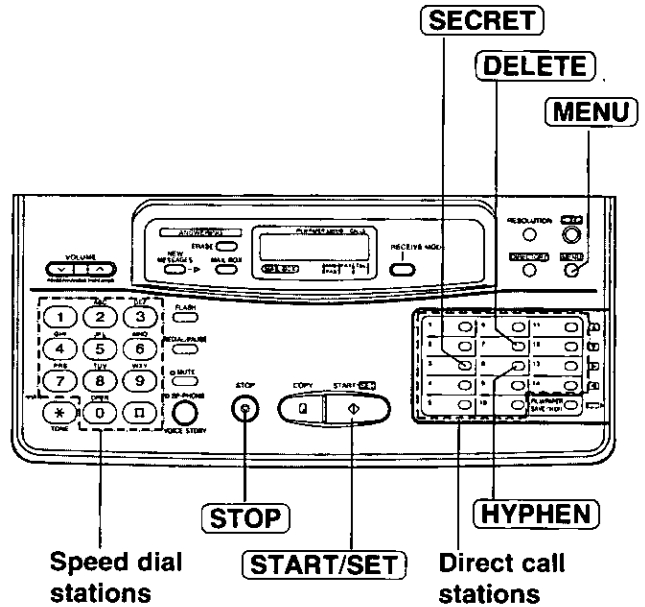

Helpful hint:

To confirm stored phone numbers and station names, print a telephone number list (see page 57).

To keep a whole or a portion of the phone number secret

Press **SECRET** (direct call station 3) before and after the number you wish to keep secret.

- The phone number will not appear on the display and on the telephone number list.
- Pressing the SECRET key once counts as two digits.

To erase a stored number and station name

Press **STOP** in step 3 to clear the phone number.

Press **DELETE** (direct call station 7) repeatedly in step 5 until all the characters are erased.

6

7

Making voice calls using automatic dialing

1 Press **SP-PHONE** or lift the handset.

2 **Using one-touch dialing:**
Press the desired direct call station key.

Using speed dialing:

Press **DIRECTORY**, then press **#** and the desired 2-digit number (00–59).

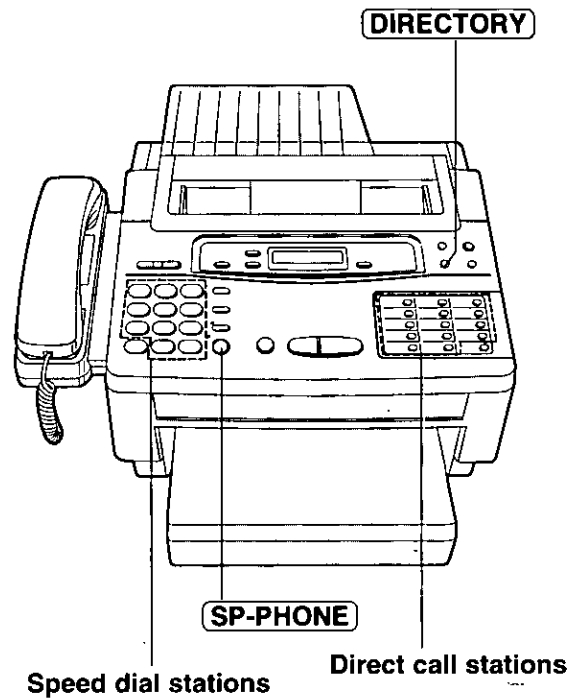

Transmitting documents using automatic dialing

1 Insert the documents FACE DOWN.

2 **Using one-touch dialing:**
Press the desired direct call station key.

Using speed dialing:

Press **DIRECTORY**, then press **#** and the desired 2-digit number (00–59).

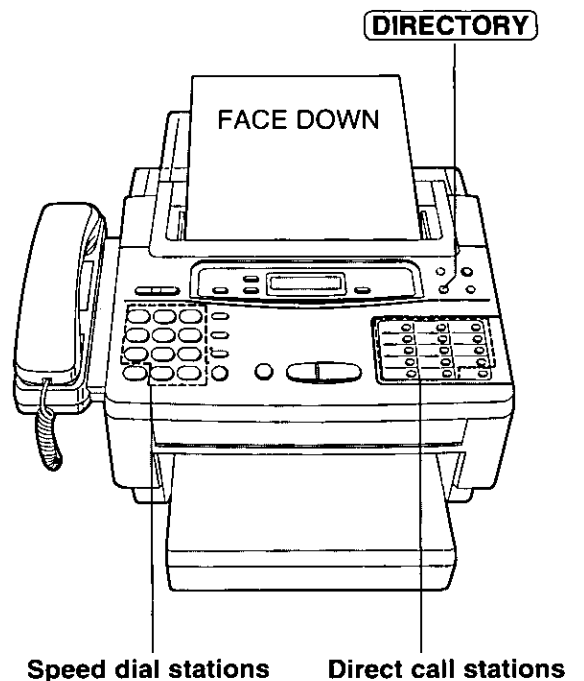

Automatic redialing

If there is no answer or the line is busy, the unit will automatically redial the number up to 5 times. To cancel the redialing, press the STOP button.

Electronic telephone directory

The station names stored in memory will be automatically registered into the electronic telephone directory in alphabetical order. You can make a fax or voice call by selecting the desired station name on the display.

If you wish to send a fax, insert the documents into the document feeder first.

1 Press **DIRECTORY**.

SELECT INDEX

2 Press the dial key in which the first initial of a station name is assigned (see index table below).

Example: To search a name with initial "N":
Press **6** repeatedly until the first station name with initial "N" is displayed. Press **▼** until the desired name is displayed.

or

Press **▲** or **▼** repeatedly until the desired name is displayed.

3 Press **START/SET**.

- The unit will start dialing.
- If a document is fed into the unit, the unit will start transmission.

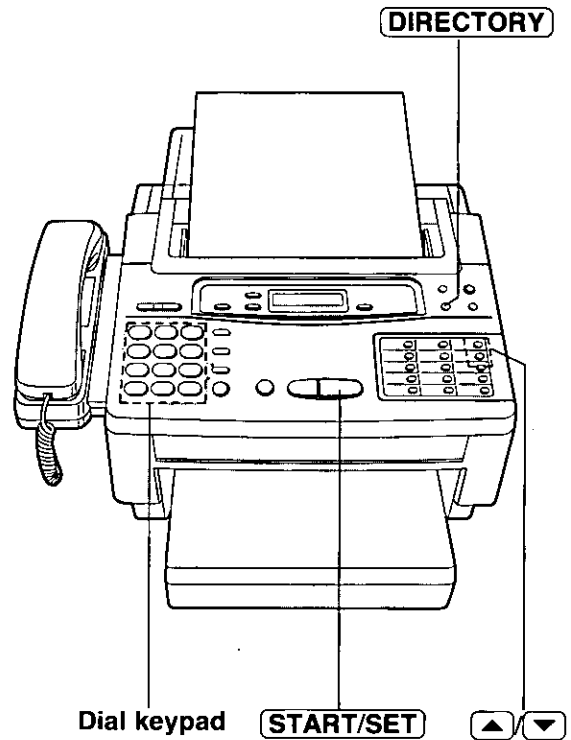

Dial key	Index	Dial key	Index
1	1	7	P, Q, R, S, 7
2	A, B, C, 2	8	T, U, V, 8
3	D, E, F, 3	9	W, X, Y, Z, 9
4	G, H, I, 4	0	0
5	J, K, L, 5	*	Other symbols
6	M, N, O, 6	#	(Used for speed dialing)

8. Advanced Operations

Voice contact

Initiating voice contact

You can have a voice conversation with the same call after the fax message is completed. This will save the extra expense and time of making another call.

Important:

This feature works only when the other party's unit is equipped with a voice contact feature.

- 1 Press **SP-PHONE/VOICE STDBY** while transmitting or receiving documents.

VOICE STANDBY

- Your unit will call the other party with a distinctive ring.

- 2 When the other party answers, the unit will emit a distinctive ring.
Press **SP-PHONE/VOICE STDBY** or lift the handset to start speaking.

- If you initiate voice contact during transmission, you can speak after all the documents have been transmitted.
- If you initiate voice contact during reception, you can speak after the current page of the document is received.

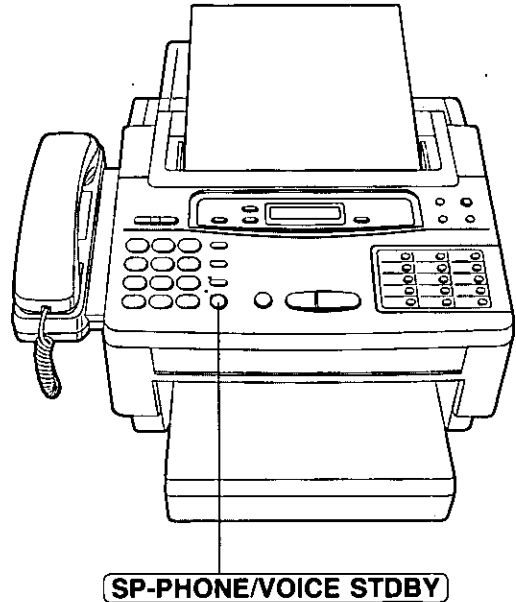

Receiving a request for voice contact

If the other party initiates voice contact, your unit will emit a distinctive ring after transmission or reception is completed.

When the distinctive ring is heard, press **SP-PHONE/VOICE STDBY** or lift the handset, then start speaking.

Note:

If you do not answer within 10 seconds of hearing the distinctive ring, one of the following occurs:

- when the unit is in the ANS/FAX mode, it will play back your greeting message and record the incoming voice message.
- when the unit is in the FAX or TEL mode, the line will be disconnected.

Polling

The polling feature allows you to receive a document from another compatible machine where you pay for the call as opposed to the document being sent to you, thereby saving the other party call charges. This unit can perform both receive and transmit polling.

Receive polling

To place a call and recover a document from another machine, follow the steps below. Make sure that no documents have been fed into your unit and that the other party's machine is ready for your call.

- 1 Press **MENU** until the following is displayed.

POLLING

- 2 Press **START/SET**.

NO. =

- 3 Enter the phone number by using one-touch dialing, speed dialing, full number dialing or electronic telephone directory.

- 4 Press **START/SET**.

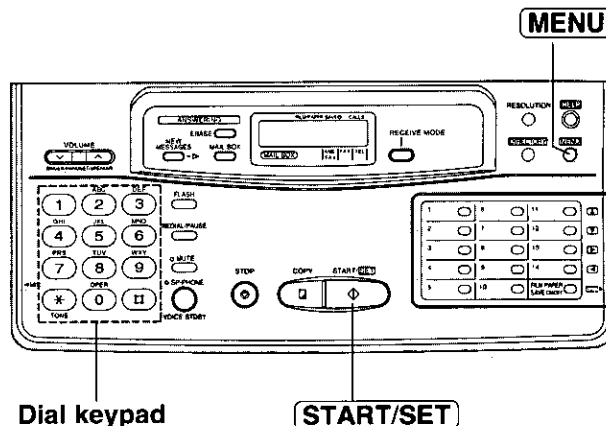

Note:

- If there is no answer or the line is busy, the unit will automatically redial the number up to 5 times.
- The receiving unit incurs any telephone charges.

Transmit polling

A document stored in your unit can be recovered by another party's machine.

To let other machines retrieve documents loaded on your unit, proceed as follows.

- 1 Press **RECEIVE MODE** to select either FAX or ANS/FAX mode.

- 2 Insert the documents FACE DOWN.

- 3 Press **MENU** until the following is displayed.

POLLED

- 4 Press **START/SET**.

MODE=OFF [▲▼]

- 5 Press ▲ or ▼ to select "ON".

MODE=ON [▲▼]

- If this feature is not required, select "OFF".

- 6 Press **START/SET**.

POLLED ON

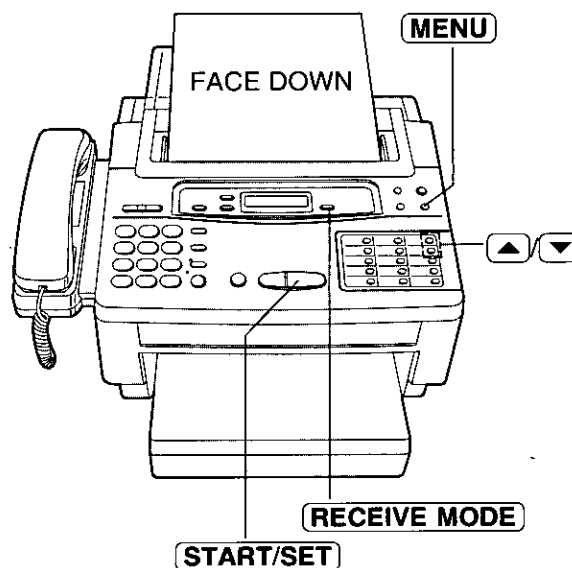

Note:

- When delayed transmission (page 32) is set to ON, this feature is not available.

Delayed transmission

The unit can send fax documents automatically at a specific time. This allows you to take advantage of low-cost calling hours offered your telephone company. Delayed transmission can be programmed up to 24 hours in advance.

- 1 Insert the documents **FACE DOWN**.
- 2 Press **MENU**.

SYSTEM SET UP
- 3 Press **#**, then press **2** **5**.

DELAYED XMT
- 4 Press **START/SET**.

MODE=OFF [▲▼]
- 5 Press ▲ or ▼ to select "ON".

MODE=ON [▲▼]

 - If this feature is not required, select "OFF".
- 6 Press **START/SET**.

NO. =
- 7 Enter the phone number by using one-touch dialing, speed dialing, full number dialing or electronic telephone directory.
- 8 Press **START/SET**.

TIME=12:00AM
- 9 Enter the transmission start time.

Example: 11:00PM
 Press **1****1****0****0**, then press **#** to select PM.
 To select AM, press *****.
- 10 Press **START/SET**.
- 11 Press **MENU**.
 - When the programmed time has come, the unit will automatically start transmission.

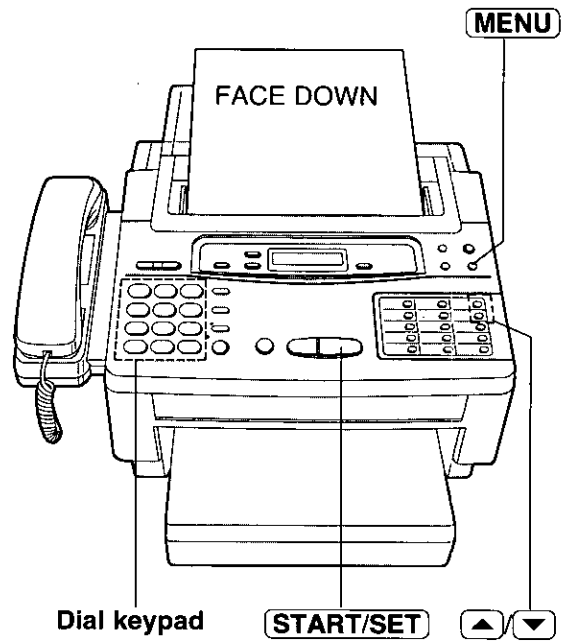

Note:

- If there is no answer or the line is busy, the unit will automatically redial the number up to 5 times.
- You can receive, transmit and copy documents while delayed transmission is set.
- If the programmed start time has passed during a power failure, delayed transmission will be attempted soon after power is restored.
- When transmit polling (see page 31) is set to ON, delayed transmission is not available.

Reserving transmission during fax reception

While the unit is receiving documents, you can reserve your fax transmission to another station. The unit will automatically transmit documents after fax reception is complete.

- 1 Insert the documents **FACE DOWN** during fax reception.
- 2 Enter the phone number by using one-touch dialing, speed dialing, full number dialing or electronic telephone directory.

•When using full number, press

START/SET.

XMT RSV. ON

To cancel the reservation

Remove the documents from the document feeder tray.

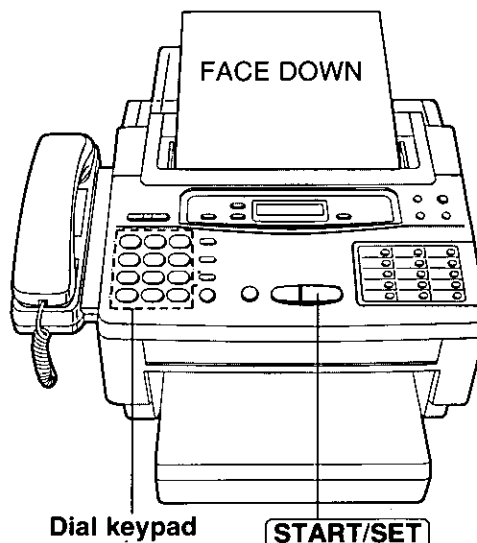

Dial keypad

START/SET

Printing a cover page

The unit can print a cover page to attach to documents you send.

Sample of a cover page

{ FAX COVER PAGE }	
TO :	NAME : _____ FAX NO. : _____
FROM :	NAME : _____ FAX NO. : _____
Number of pages :	_____ (including cover page)
Subject / Notes :	_____
	DATE : _____

To print a cover page, proceed as follows:

- 1 Press **MENU** until the following is displayed.

PRINT LIST

- 2 Press **#**, then **7**.

FAX COVER PAGE

- 3 Press **START/SET** to start printing.

PRINTING

- 4 Press **MENU**.

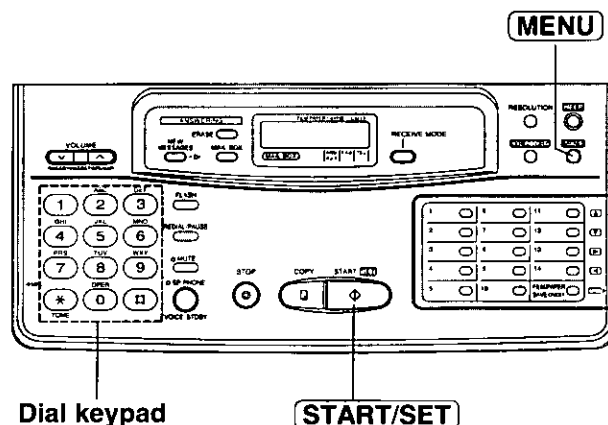

Dial keypad

START/SET

Remote fax receiving using an extension

If you have an extension phone on the same line, it is possible to receive a fax message to your facsimile unit. Using the extension phone, dial the remote fax activation code.

This saves you from going to the facsimile unit and pressing **START/SET**.

Important:

- To activate this feature, use a touch tone telephone as the extension phone.
- The remote fax activation code is set to “**” as a preselected setting.

Using an extension

- 1 When a call is received, lift the handset of the extension phone.
- 2 When:
 - document reception is required, or
 - a slow beep is heard, or
 - no sound is heard,
 press ** (remote fax activation code).
- 3 Replace the handset.
 - The facsimile unit will activate the fax function to receive documents.

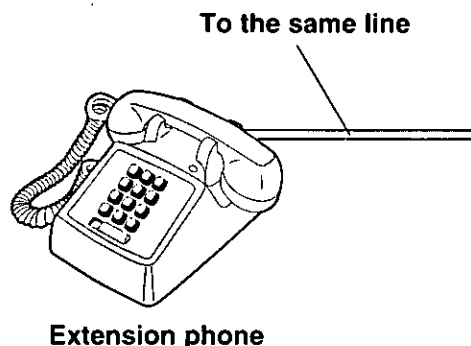

Changing the remote fax activation code

This code can be from 1 to 4 digits in length using the numbers 0 through 9 and the character *. This code should not be set to “0000”.

- 1 Press **MENU**.
 SYSTEM SET UP
- 2 Press **#**, then **4 1**.
 REMOTE FAX ACT.
- 3 Press **START/SET**.
 CODE=**
- 4 Enter the new code number.
- 5 Press **START/SET**.
- 6 Press **MENU**.

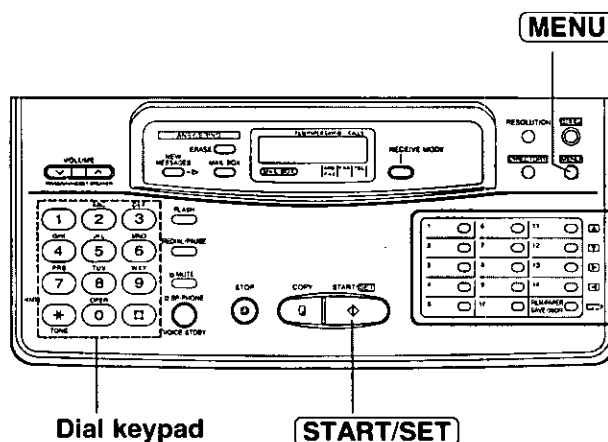

Note:

Some special telephone company services will require you to press a service access code. If you subscribe to such services, the whole or part of the remote fax activation code must be different from the service access code.

Junk mail prohibitor

This feature prevents reception from facsimile machines whose phone numbers are not stored in automatic dialing.

Important:

- This feature is available when the unit is in the ANS/FAX or FAX mode.
- This feature does not work under the following conditions:
 - when manual reception is performed, or
 - the other party does not program their facsimile ID number correctly.
- If you wish to receive documents from unauthorized machines, inform your junk mail prohibitor ID to callers, and ask them to transmit documents manually.
- The junk mail prohibitor ID must be different from the first 2 digits of the remote ANS ID (page 42) and a mailbox password (page 39). e.g. if the remote ANS ID is "321", do not use "32" as a junk mail prohibitor ID.

Setting the junk mail prohibitor

1 Press **MENU**.

SYSTEM SET UP

2 Press **#**, then **2****4**.

JUNK MAIL PROH.

3 Press **START/SET**.

MODE=OFF [▲▼]

4 Press **▲** or **▼** to select "ON".

MODE=ON [▲▼]

- If this feature is not required, select "OFF".

5 Press **START/SET**.

ID=22

6 To change the junk mail prohibitor ID, enter the desired 2-digit number.

- 0, # and * cannot be used.

7 Press **START/SET**.

8 Press **MENU**.

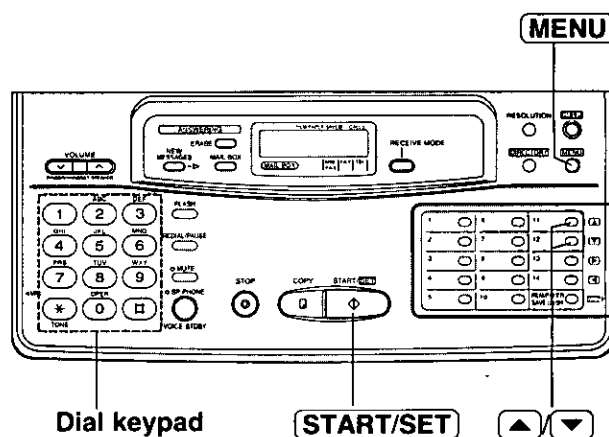

Transmitting documents to your unit with the prohibitor ID

Even if the junk mail prohibitor feature is activated, a designated caller will be able to transmit documents. Give your junk mail prohibitor ID to all your designated callers, and advise them of the following steps. This operation is available only when your unit is in the ANS/FAX mode.

1. Call your unit from a touch tone telephone.
2. Dial the prohibitor ID while the greeting message is playing.
3. Listen for the fax tone, and start transmission.

Receiving with distinctive ring service

This feature enables you to use the distinctive ring service provided by your telephone company effectively.

The distinctive ring service gives you up to 3 phone numbers on a single telephone line, each will have a different ringing pattern.

When you wish to use one of the phone numbers as a facsimile telephone number, program the ringing pattern assigned for fax into your unit. When the unit detects a call matching the selected distinctive ringing pattern, the unit will automatically activate the fax function to receive documents.

To use this feature effectively, set the unit to the ANS/FAX mode.

The unit will work as follows.

How the unit will answer in the ANS/FAX mode

When a distinctive ringing pattern that matches your selection is detected, the unit will automatically answer the line and activate the fax function to receive documents. If other ringing patterns are received, the unit will activate fax function and/or answering device depending on the call.

Note:

- The unit automatically answers a distinctive ring call after the second ring. To change the number of rings, change the FAX ring count (page 21) after setting the ring detection feature.
- When in the TEL mode, you have to answer all calls manually.
- When in the FAX mode, the unit will automatically answer all calls and activate fax function.
- For more information on the distinctive ring service, please contact your telephone company.

Programming the distinctive ringing pattern

Ringing patterns that can be programmed:

OFF: Turns off the ring pattern detection feature (initial setting)

A: Standard ring (One long ring)

B: Double ring (Two short rings)

C: Triple ring (Short-long-short rings)

D: Other triple ring (Short-short-long rings)

1 Press **MENU**.

SYSTEM SET UP

2 Press **#**, then **3** **1**.

RING DETECTION

3 Press **START/SET**.

MODE=OFF [▲▼]

4 Press **▲** or **▼** to select the desired mode.

5 Press **START/SET**.

6 Press **MENU**.

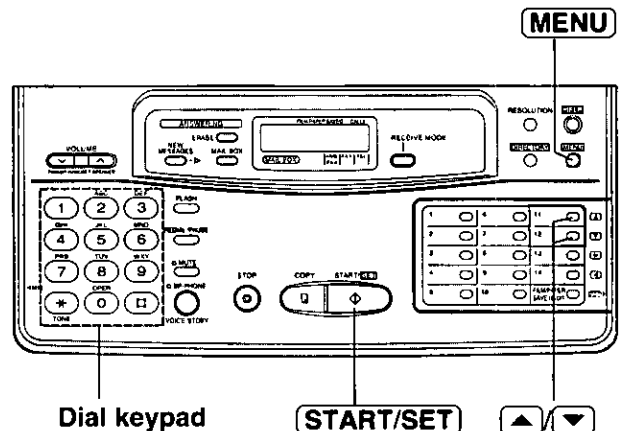

Voice mailbox

The unit has four memory locations—common memory and three mailboxes. The greeting messages and incoming calls can be recorded into each memory location.

Your caller can leave a message in a specific mailbox. Only the person who knows the password can retrieve the message from the mailbox.

If your caller does not specify a mailbox, their message will be recorded in common memory and anyone can retrieve the message from memory.

This feature is useful when you use the unit with other people and when your caller would like to record a message directly to you.

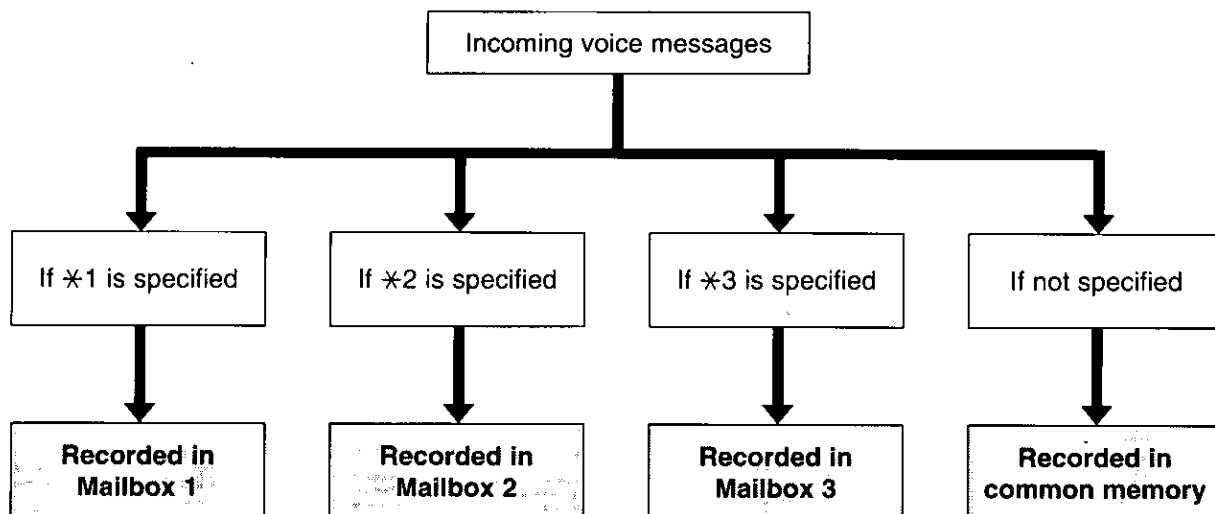

To use a mailbox

1. Record a common greeting message into common memory (page 15).
2. Record personal greeting message(s) into the mailbox(es).
3. Program each mailbox password.
4. In order to leave a message in a mailbox, each owner of the mailbox must inform callers of their mailbox number in advance.

Recording a mailbox greeting message

Record a personal greeting message for each mailbox. This will be played back to the caller who selected the specific mailbox.

Helpful hints:

- Each greeting message can be recorded up to 16 seconds. We recommend you record a brief greeting message to leave more time for incoming messages.
- If you do not record a mailbox greeting message, incoming messages will be recorded after the long beep.

- 1 Open the station key panel.
- 2 Press **SELECT** until the desired mailbox number is displayed.

Example: Mailbox 2

BOX2-GREETING

- 3 Press **REC**.
 - A long beep will sound.
- 4 Immediately after the long beep, speak clearly into the microphone.
 - The display shows the elapsed recorded time.

BOX2 REC. 02s

- 5 When finished, press **STOP**.

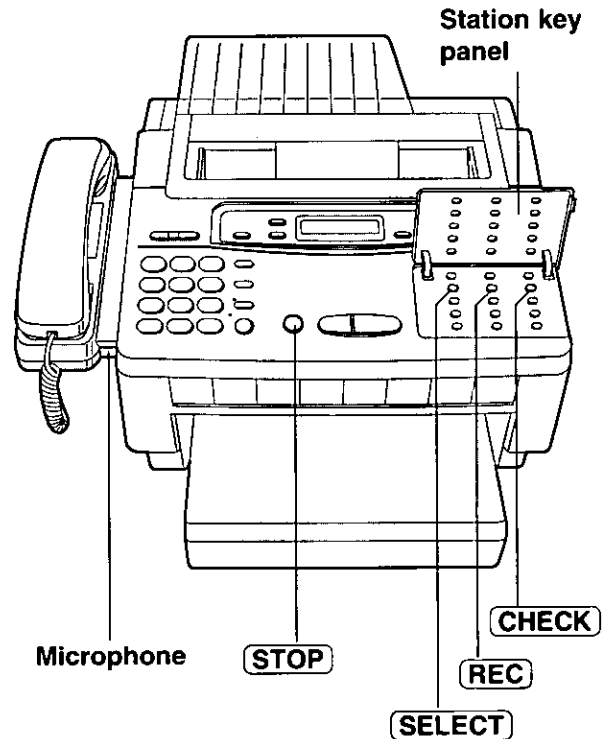

Suggested message

"Hello, this is John. Sorry, I cannot take your call. Please leave your message after the beep. Thank you."

To check your mailbox greeting message

1. Press **SELECT** until the desired mailbox number is displayed.
2. Press **CHECK**.

To erase a mailbox greeting message

1. Press **SELECT** until the desired mailbox number is displayed.
2. Press **REC**.
3. Press **STOP** immediately after a long beep.

Programming the mailbox password

Program your own password for your mailbox to prevent other users from retrieving messages. Choose any 3-digit number except a number using digits 0 or 7.

1 Press **MENU**.

SYSTEM SET UP

2 For mailbox 1, press **#**, then **5** **1**.

BOX1 PASSWORD

For mailbox 2, press **#**, then **5** **2**.

BOX2 PASSWORD

For mailbox 3, press **#**, then **5** **3**.

BOX3 PASSWORD

3 Press **START/SET**.

NO. =

4 Enter the new password (111–999).

5 Press **START/SET**.

- To program other passwords, repeat from step 2.

6 Press **MENU**.

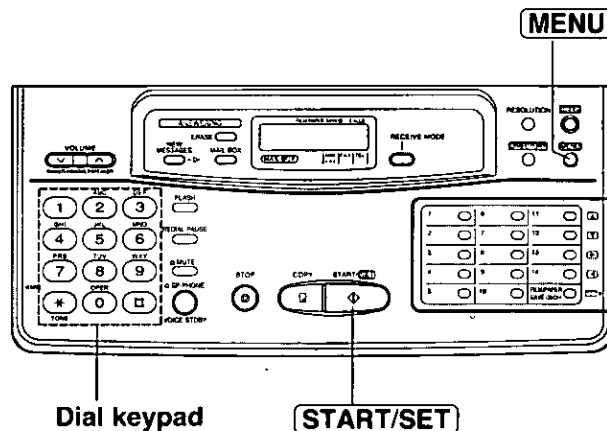

How incoming messages are recorded in a mailbox

In order to leave a message in a mailbox, each owner of a mailbox must inform their callers of their mailbox number in advance and set the unit to the ANS/FAX mode.

1 A caller calls your unit (from a touch tone telephone only).

- The common greeting message will play.

2 They press *****, then the desired mailbox number (1–3).

- Personal greeting message will play, followed by a long beep.

3 They leave a message in the mailbox.

Note:

If a caller does not specify a mailbox in step 2, the message will be recorded into common memory.

Listening to messages in a mailbox

When there is a new message in a mailbox,
 —the mailbox number will flash in the display.
 —a slow beep will sound if mailbox alert (page 53) is set to ON.

- 1 Press **MAIL BOX** repeatedly until the desired mailbox number is displayed.

BOX2 02

- 2 Enter the mailbox password.

Example: The password 555 (factory setting)

PASSWORD=555

- The unit will play back the new recorded messages.
- If no new messages are recorded, the unit will play back all of the recorded messages.

- 3 To exit the mailbox, press **MAIL BOX**.

Note:

- The REPEAT, SKIP and STOP buttons can be used.
- If you leave the mailbox password as "555" (factory setting), you need not enter a password. Press **NEW MESSAGES** or **ALL MESSAGES** instead of a password.

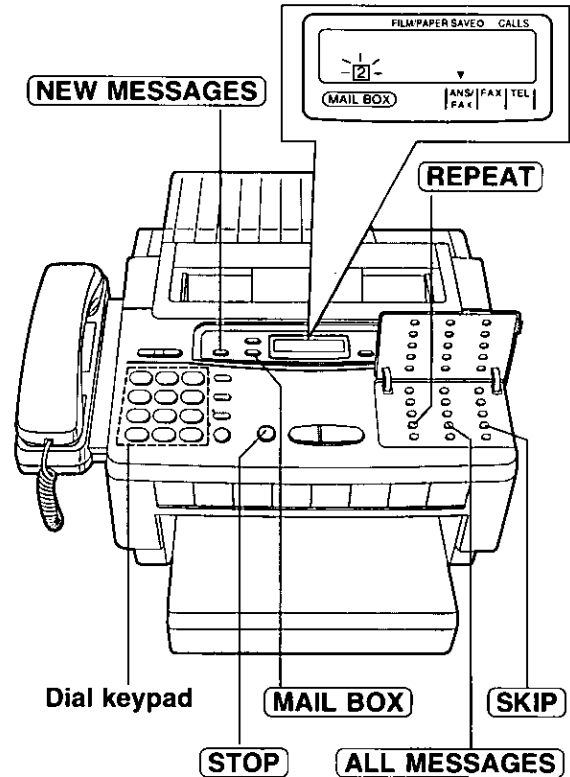

Erasing recorded messages in a mailbox

Erasing a specific message in a mailbox

Press **ERASE** while the message you want to erase is playing.

Erasing all messages in a mailbox

- 1 Press **MAIL BOX** repeatedly until the desired mailbox number is displayed.
Example: Mailbox 1 is selected.

- 2 Press **ERASE**.

BOX1 ERASE OK?

- 3 Press **START/SET**.

ERASE COMPLETED

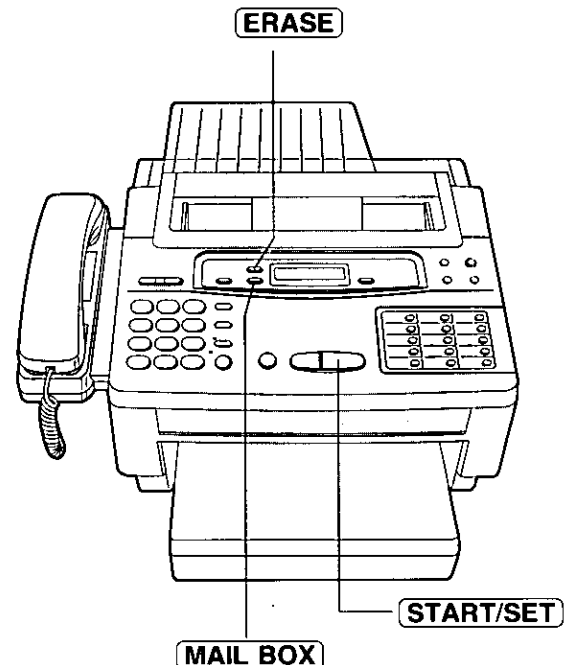

Remote operation from a touch tone phone

You can access your unit and retrieve the incoming messages from a remote location with a touch tone telephone.

Summary of remote operations

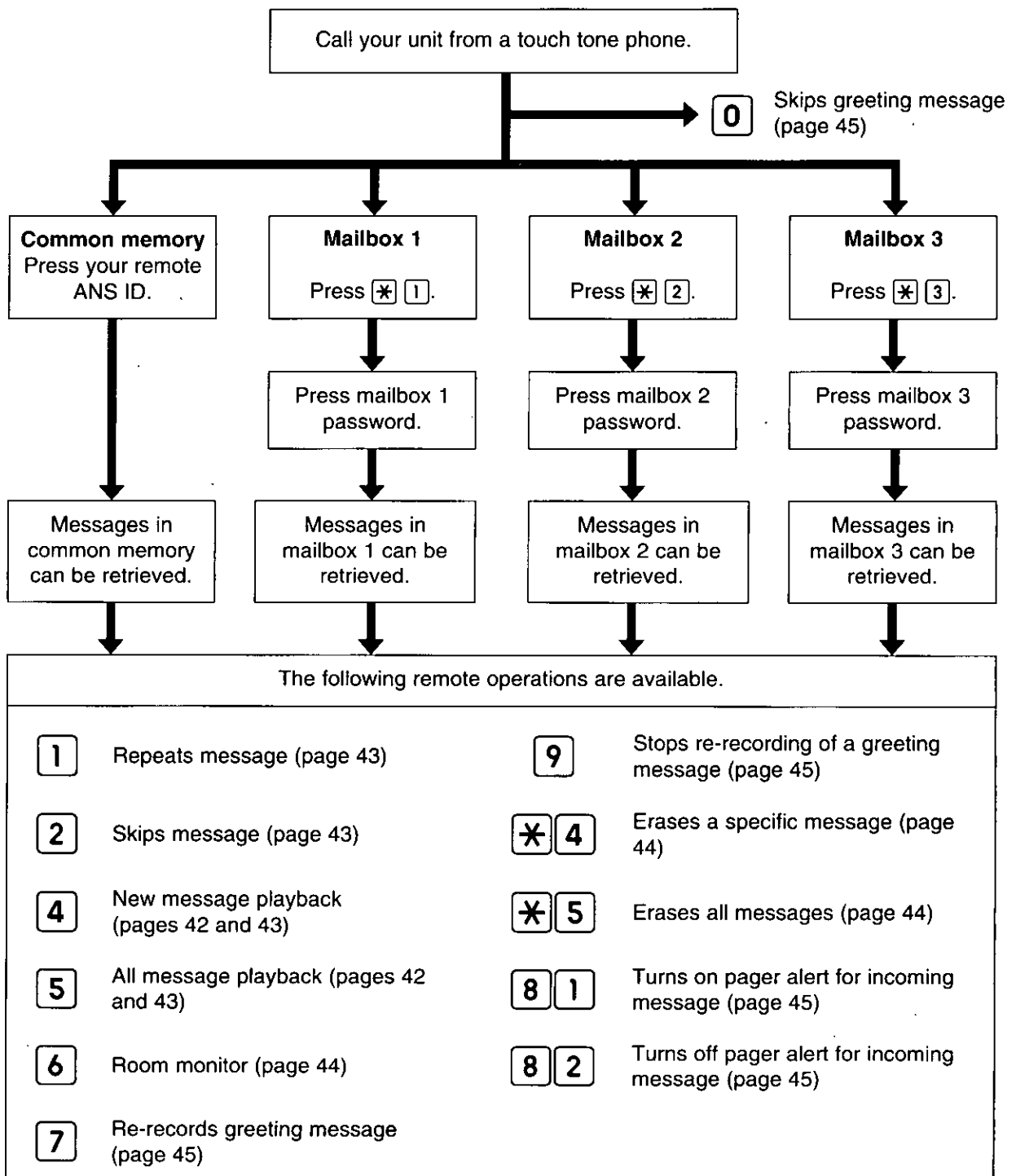

Programming the remote ANS ID

The remote ANS ID is used to access your answering device and listen to your messages in common memory.

Choose any number from 111 to 999 except a number using digits 0 or 7.

Make sure that the first 2-digits of the remote ANS ID are different from the junk mail prohibitor ID.

1 Press **MENU**.

SYSTEM SET UP

2 Press *****, then **10**.

REMOTE ANS ID

3 Press **START/SET**.

ID=111

4 Enter the desired number.

5 Press **START/SET**.

6 Press **MENU**.

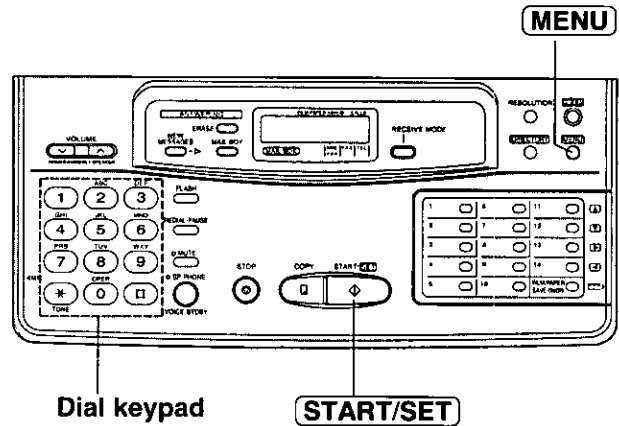

Listening to messages in common memory

1 Call your unit.

2 Press the remote ANS ID during common greeting playback.

- A long beep and a short beep(s) will sound.
- Short beep(s) indicate(s) the number of new recorded messages.
- Short beeps will sound up to 8 times even if 9 or more calls are recorded.

3 Press **4** to listen to new recorded messages.
OR

Press **5** or wait for 4 seconds to listen to all of the recorded messages.

Note:

If you hear 6 beep tones after playing back the messages, memory is full. You must erase some or all of the messages.

To listen to messages in a mailbox after playback

1. Press ***** and the desired mailbox number **1**, **2** or **3**.
2. Press the mailbox password.
3. Press the direct remote command **4** or **5** to play back messages.

Listening to messages in a mailbox

- 1 Call your unit.
- 2 Press ***** and the desired mailbox number (**1**, **2**, **3**) during common greeting playback.
- 3 Enter a mailbox password during a personal greeting message.
 - A long beep and a short beep(s) will sound. Short beep(s) indicate(s) the number of newly recorded messages. Short beeps will sound up to 8 times even if 9 or more calls are recorded.
- 4 Press **4** to listen to newly recorded messages.
OR
Press **5** or wait for 4 seconds to listen to all the recorded messages.

Note:

If you hear 6 beep tones after playing back the messages, memory is full. You must erase some or all of the messages.

To listen to messages in another memory after playback:

1. Press *****, and **0** (for common memory),
or
press ***** and other mailbox number **1**,
2 or **3**.
2. If you selected common memory, press the remote ANS ID.
or
If you selected a mailbox, press the mailbox password.
3. Press the direct remote command **4** or **5** to play back messages.

During playback

Repeating a message

Press **1** to start playing the previous message.

Skipping a message

Press **2** to start playing the next message.

Erasing messages from memory

Erasing a specific message from memory

Press *** 4** when the message you want to erase is being played.

- The unit will erase the message being played back.
- A long beep followed by three short beeps will sound. Then the unit will continue with the next message.

Erasing all messages from memory

You can erase all of the recorded messages in memory.

To erase all of the messages in a mailbox, you must first select a mailbox.

Press *** 5**.

- A long beep followed by three short beeps will sound.
- The unit will erase all of the messages recorded in the selected memory.

Note:

The greeting messages will not be erased during this operation.

Other remote operations

Monitoring the room sound

You can monitor the sound in the room where the unit is installed for about 30 seconds. This feature also allows you to speak with anyone in the room.

- 1 Call your unit.
- 2 Press your remote ANS ID.
OR
Press *** 4**, then press your mailbox number.
- 3 Press **6** after hearing a beep.
 - After 30 seconds are up, a beep sounds.
 - To continue monitoring, press **6** again within 10 seconds.
 - To talk to the other party, tell them to lift the handset or press **SP-PHONE**.

Recording a marker message

After playing back the recorded messages, you can leave an additional message.

- 1 Wait for 3 beeps indicating the end of the remote operation.
- 2 Wait about 10 seconds for 2 more beeps indicating that the unit is ready for recording.
- 3 Leave your message.

Re-recording a greeting message

You can change the content of the greeting message from a remote location.

- 1 Call your unit.
- 2 **For the common greeting message:**
Press your remote ANS ID.

For the mailbox greeting message:
Press ***** and **1**, **2** or **3** (desired mailbox no.). Then press the mailbox password.
- 3 Press **7** to start recording.
 - A long beep will sound.
- 4 Speak immediately after the long beep (up to 16 seconds).
 - If you pause for over 2 seconds while recording, the unit will beep and stop the greeting message recording. Repeat from step 2 within 10 seconds.
- 5 When finished, press **9**.
 - The new greeting message will be played.

Turning on/off pager alert

You can remotely turn on/off the pager alert for incoming message if it has been programmed with a pager number in advance (see page 54).

- 1 Call your unit.
- 2 **For the common pager alert;**
Press the remote ANS ID.

For a mailbox pager alert;
Press ***** and the mailbox number (**1**, **2** or **3**), then press the mailbox password.
- 3 To turn on the pager alert, press **81**.
To turn off the pager alert, press **82**.

To skip the greeting message

Callers can record their messages without listening to the greeting message.

After calling your unit, dial **0** during the greeting message playback.

- The unit will skip the rest of the greeting message and start recording.

Logo print position

Logo, telephone number, date, time and page number will be printed on the transmitted document from your unit in the following manner.

OUT: Outside of the transmitted document's paper size. (pre-selected setting)

IN: Inside of the transmitted document's paper size.

OFF: Not printed.

To change the setting, proceed as follows.

1 Press **MENU**.

SYSTEM SET UP

2 Press **#**, then **21**.

LOGO POSITION

3 Press **START/SET**.

MODE=OUT [▲▼]

4 Press **▲** or **▼** to select the desired setting.

5 Press **START/SET**.

6 Press **MENU**.

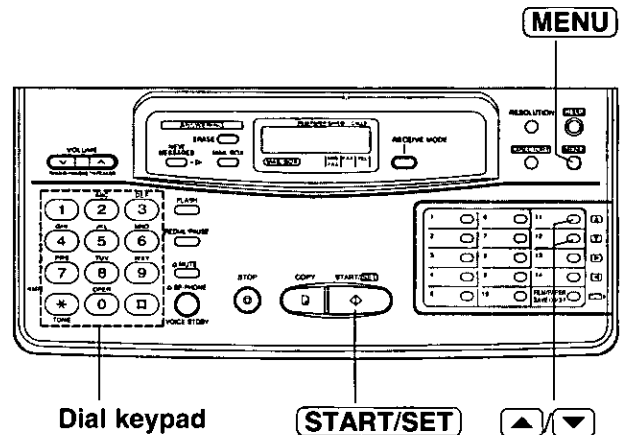

Overseas transmission mode

You may experience difficulty in transmitting documents overseas.

This feature will make sending documents easier as the transmission speed is slowed down.

1 Press **MENU**.

SYSTEM SET UP

2 Press **#**, then **23**.

OVERSEAS MODE

3 Press **START/SET**.

MODE=OFF [▲▼]

4 Press **▲** or **▼** to select "ON".

MODE=ON [▲▼]

• If this feature is not required, select "OFF".

5 Press **START/SET**.

6 Press **MENU**.

• Then start transmission procedure (see pages 18 and 19).

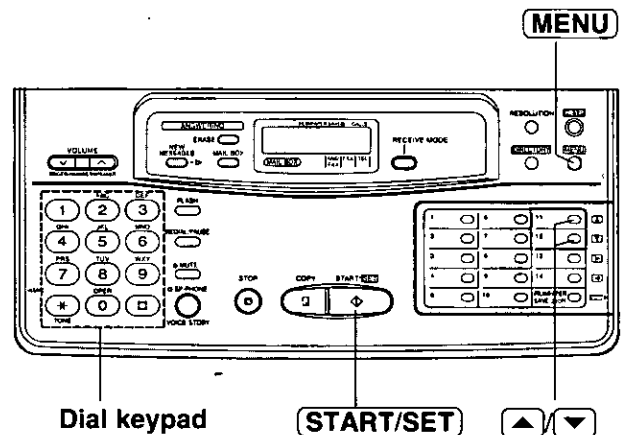

Note:

- After the transmission has completed, this feature will be turned off automatically.
- When using this feature, transmission time will increase.

Copy reduction mode

When you copy documents that are longer than the recording paper, the unit can reduce the original document and print it out on one page by programming a suitable reduction rate below. The reduction rate is determined by a combination of the size of recording paper and original document.

■ Recommended reduction rate:



Mode	Size of recording paper	Size of original document
OFF (pre-selected)	Letter	Letter
	Legal	Letter, A4, Legal
92%	Letter	A4
72%	Letter	Legal

Letter=216×279 mm (8½"×11")

Legal=216×356 mm (8½"×14")

A4 =210×297 mm (may not be available in the United States.)

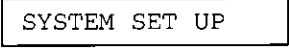
To program a reduction rate, proceed as follows.

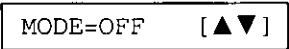
- 1 Press **MENU**.

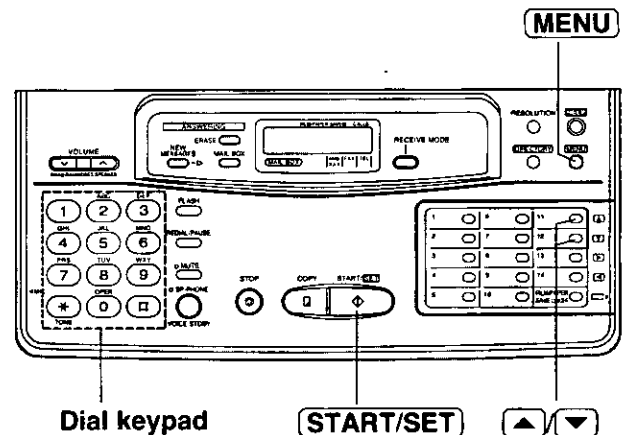
- 2 Press **#**, then **3** **5**.

- 3 Press **START/SET**.

- 4 Press **▲** or **▼** to select the desired mode.
- 5 Press **START/SET**.
- 6 Press **MENU**.



Note:

If the appropriate reduction rate is not programmed the document may be divided and the top of the second sheet will be deleted.

Receiving reduction mode

When the size of the documents sent by the other party is as large as, or larger than the recording paper, the unit can reduce each page of the document and print it out on the recording paper at a suitable reduction rate below.

The reduction rate is determined by a combination of the size of the recording paper and received document.

■ Recommended reduction rate:

Mode	Size of recording paper	Size of received document
OFF	Legal	Letter, A4
92% (pre-selected)	Letter	Letter
	Legal	Legal
86%	Letter	A4
72%	Letter	Legal

Letter=216×279 mm (8½"×11")

Legal=216×356 mm (8½"×14")

A4 =210×297 mm (may not be available in the United States.)

To program a reduction rate, proceed as follows.

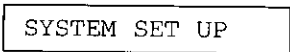
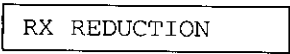
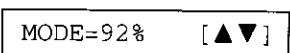
- 1 Press **MENU**.

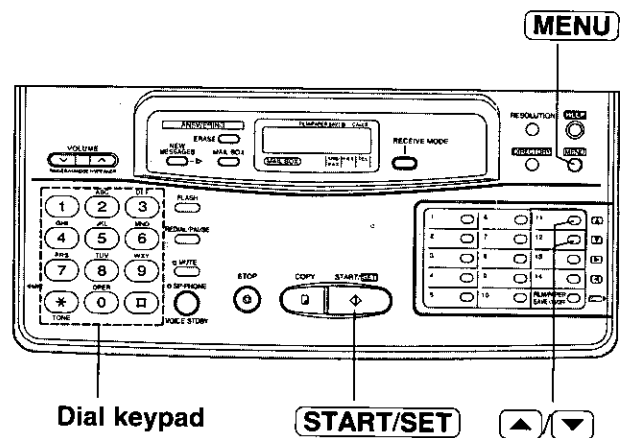
- 2 Press **#**, then **3** **6**.

- 3 Press **START/SET**.

- 4 Press **▲** or **▼** to select the desired mode.
- 5 Press **START/SET**.
- 6 Press **MENU**.



Note:

- This feature is not available when the film/paper save reception feature is set to ON (page 49).
- Documents received by facsimile frequently have a heading on the top of each page which contains the sender's name/phone number. This increases the length of each page. Therefore, it is recommended to use the reduction mode.
- If the appropriate reduction rate is not programmed, the over-sized document will be divided.

Film/Paper save reception

Use this feature if you wish to save film and recording paper when receiving two or more faxed pages. When this feature is set, the unit will reduce documents to half their length and print out two pages of documents on one page. A boundary will be printed out between the documents.

Important:

This feature will not work when the other party sends a document in fine resolution or other nonstandard resolutions.

Sample of paper save print:

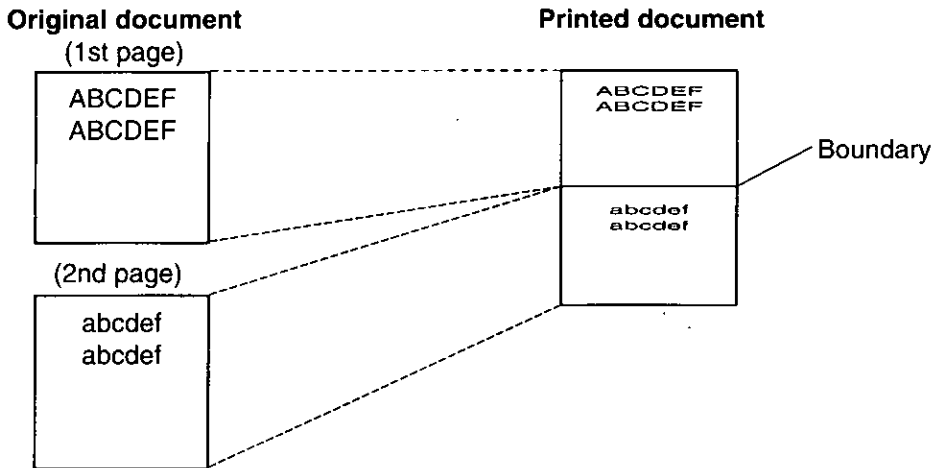

To activate this feature

- 1 Press **FILM/PAPER SAVE**.
 - The following messages will be alternately displayed.

PAPER SAVE=ON?

YES: PRESS SET

- 2 Press **START/SET**.

FILM/PAPER SAVE

- The arrow mark will be displayed.

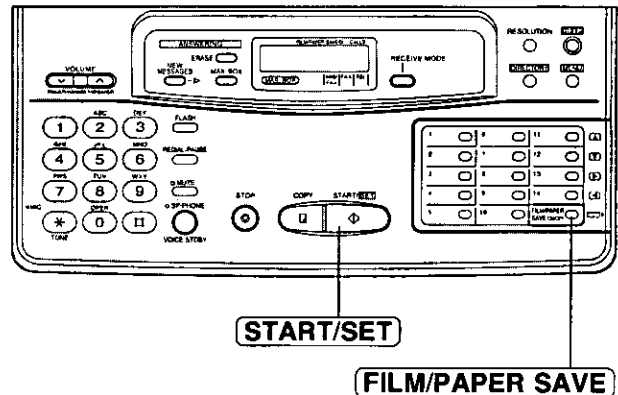

To deactivate this feature

- 1 Press **FILM/PAPER SAVE**.
 - The following messages will be alternately displayed.

PAPER SAVE=ON?

YES: PRESS SET

- 2 Press **START/SET**.

- The arrow mark will be displayed.

Note:

- When a reduced document is longer than the recording paper, it will be printed on two pages. The continuation will be printed on next page and there may be wasted space. In this case, paper and film will not be saved for the wasted space.
- When documents are longer than legal size, the unit will not print the next page of the document on the same page.
- Paper and film will not be saved for one page document and the last page of odd numbered documents.

Extension copy

Use this feature to enlarge a document to twice the length of the paper that is correctly being used in the paper cassette. This feature is used to reverse the film/paper save function (see page 49).

Sample of extension copy:

When you wish to enlarge the top half of the document:

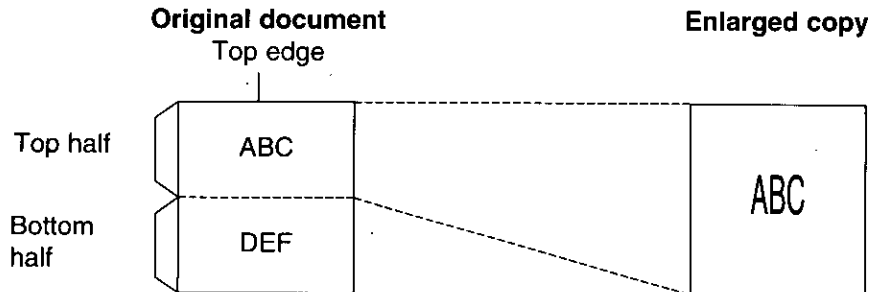

Insert a document into the unit from the top edge side FACE DOWN.

To activate this feature, proceed as follows:

1 Insert the documents FACE DOWN.

2 Press **MENU**.

3 Press **#**, then **3** **4**.

4 Press **COPY**.

•The unit will start printing.

5 After printing, press **MENU**.

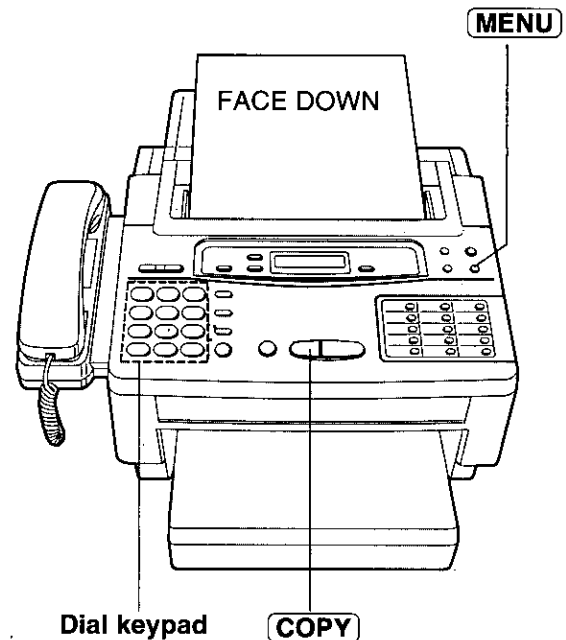





Note:

- You cannot select FINE or HALF TONE resolution for this feature.
- To make an enlarged copy of the whole page whose length is as long as, or shorter than your installed paper:
First insert the top half of the original document into the feeder tray and copy. Then turn the original around and insert the bottom half of the document into the feeder tray and copy.

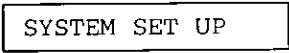
Pager alert for fax reception

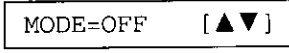
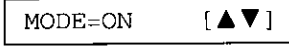
This feature allows your unit to call your pager automatically each time your unit receives a fax message.

- 1 Press **MENU**.

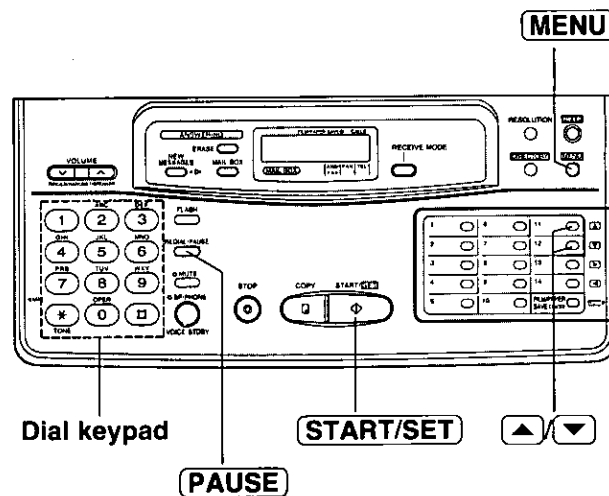
- 2 Press **#**, then **70**.

- 3 Press **START/SET**.

- 4 Press **▲** or **▼** to select "ON".

 - If this feature is not required, select "OFF".
- 5 Press **START/SET**.

- 6 Enter your pager phone number.
 If necessary, press **PAUSE** twice.
 Contact your pager company regarding the proper pause time.
- 7 If your pager has the ability to display phone numbers, enter the number that you wish to appear in the display.
 Press **#** if required by your pager company.
- 8 Press **START/SET**.
- 9 Press **MENU**.



Note:

You may enter a total of 30 digits and/or pauses in steps 6 and 7.

Setting the caller's recording time

You can choose between two lengths of recording times for incoming messages.

VOX (unlimited): The unit will record an incoming message as long as the caller speaks (pre-selected setting).

1 MIN (1 minute): The unit will record an incoming message up to 1 minute per message.

- 1 Press **MENU**.
- 2 Press **#**, then **09**.
- 3 Press **START/SET**.
- 4 Press **▲** or **▼** to select the desired mode.
- 5 Press **START/SET**.
- 6 Press **MENU**.

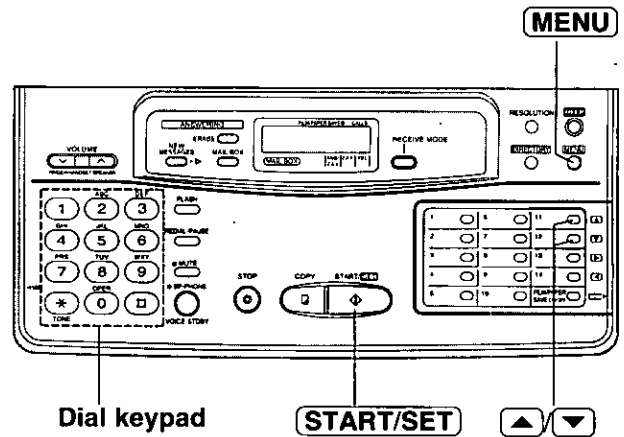

Message alert

This feature allows your unit to alert you with a slow beep if a caller's message has been recorded in common memory.

- 1 Press **MENU**.
- 2 Press **#**, then **42**.
- 3 Press **START/SET**.
- 4 Press **▲** or **▼** to select "ON".

•If this feature is not required, select "OFF".

- 5 Press **START/SET**.
- 6 Press **MENU**.

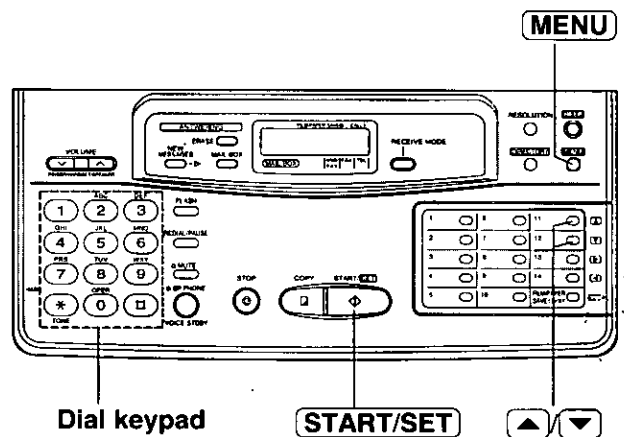

Note:

This feature does not work for the mailbox feature.

Recording time alert

When the remaining time to record incoming messages becomes less than 60 seconds, the unit will alert the user with a slow beep.

1 Press **MENU**.

SYSTEM SET UP

2 Press **#**, then **43**.

REC. TIME ALERT

3 Press **START/SET**.

MODE=OFF [▲▼]

4 Press ▲ or ▼ to select "ON".

MODE=ON [▲▼]

•If this feature is not required, select "OFF".

5 Press **START/SET**.

6 Press **MENU**.

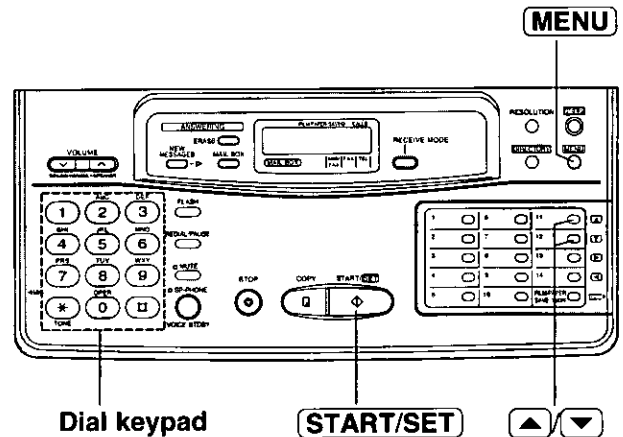

Mailbox alert

This feature allows your unit to alert you with a slow beep if a caller's message has been recorded in a mailbox.

1 Press **MENU**.

SYSTEM SET UP

2 Press **#**, then **50**.

MAIL BOX ALERT

3 Press **START/SET**.

MODE=OFF [▲▼]

4 Press ▲ or ▼ to select "ON".

MODE=ON [▲▼]

•If this feature is not required, select "OFF".

5 Press **START/SET**.

6 Press **MENU**.

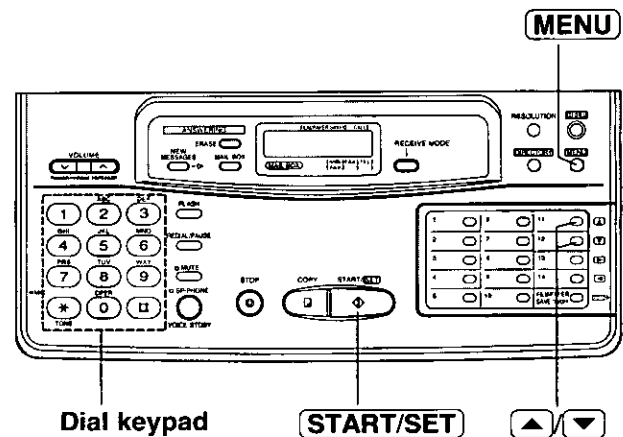

Pager alert for incoming messages

This feature allows your unit to call your pager automatically each time an incoming message is recorded. You can set the pager number for each memory (common, mailbox 1, 2 and 3).

1 Press **MENU**.

SYSTEM SET UP

2 For common pager alert, press **#**, then **60**.

COMMON PAGER

For mailbox 1 pager alert, press **#**, then **61**.

MAIL BOX1 PAGER

For mailbox 2 pager alert, press **#**, then **62**.

MAIL BOX2 PAGER

For mailbox 3 pager alert, press **#**, then **63**.

MAIL BOX3 PAGER

3 Press **START/SET**.

MODE=OFF [▲▼]

4 Press **▲** or **▼** to select "ON".

MODE=ON [▲▼]

•If this feature is not required, select "OFF".

5 Press **START/SET**.

NO. =

6 Enter your pager phone number.
If necessary, press **PAUSE** twice.
Contact your pager company regarding the proper pause time.

7 If your pager has the ability to display phone numbers, enter the number that you wish to appear on the display.
Press **#** if required by your pager company.

8 Press **START/SET**.

9 Press **MENU**.

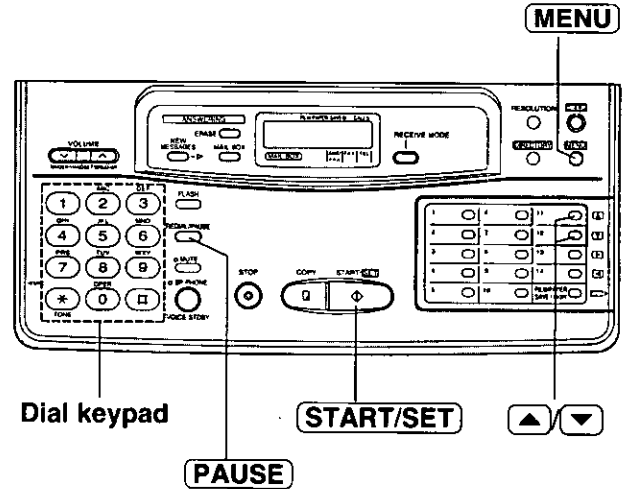

Note:

- You may enter a total of 30 digits and/or pauses in steps 6 and 7.
- This feature can be turned on/off remotely from a touch tone phone (see page 45).

Display contrast

Use this feature to adjust the brightness of the display. The following choices are available.

NORMAL: (Pre-selected)

LIGHT: Used when the display contrast is dark.

DARKER: Used when the display contrast is light.

1 Press **MENU**.

SYSTEM SET UP

2 Press **#**, then **39**.

LCD CONTRAST

3 Press **START/SET**.

MODE=NORMAL [▲▼]

4 Press ▲ or ▼ to select the desired mode.

5 Press **START/SET**.

6 Press **MENU**.

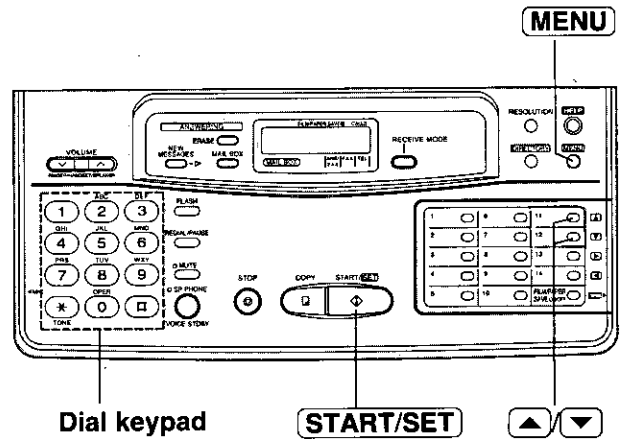

Resetting the advanced features

Use this feature to return the advanced features (see page 60) to their initial settings.

1 Press **MENU**.

SYSTEM SET UP

2 Press **#**, then **80**.

SET DEFAULT

3 Press **START/SET**.

RESET=NO [▲▼]

4 Press ▲ or ▼ to select "YES".

RESET=YES [▲▼]

5 Press **START/SET**.

RESET OK?

• If this feature is not required, press **STOP**.

6 Press **START/SET** again for confirmation.

RESET COMPLETED

7 Press **MENU**.

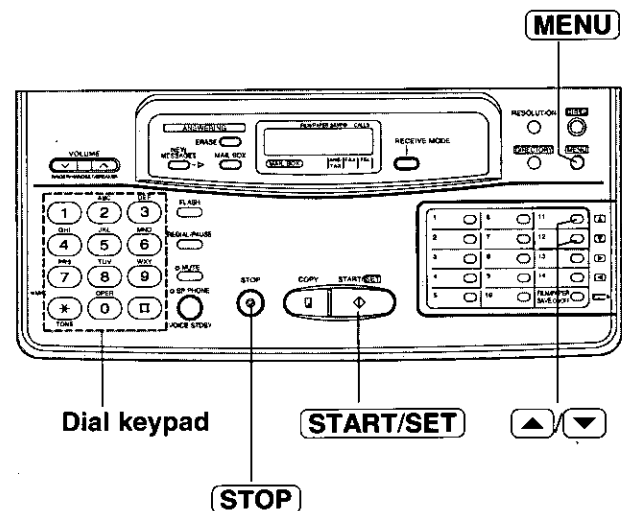

TONE, FLASH and PAUSE buttons

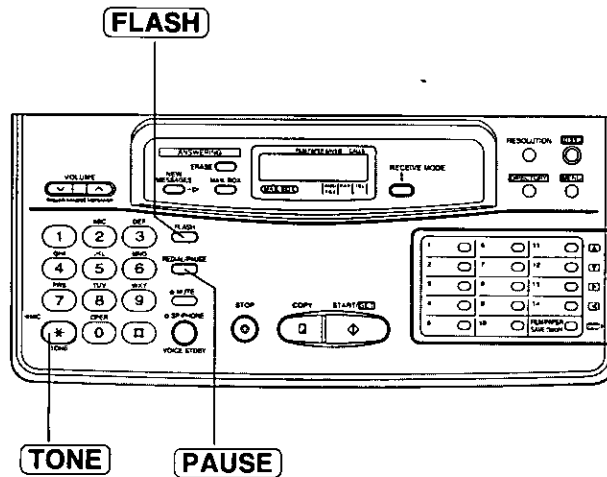

TONE button

The TONE (*) button is used when your line has a rotary pulse dial service. Pressing the button allows you to change temporarily from pulse to tone mode during a dialing operation. When you hang up, the unit will automatically return to pulse mode.

FLASH button

The FLASH button functions as the hookswitch on a regular phone. If you misdial or dial another phone number, press the FLASH button firmly. The call will be terminated and you will hear dial tone. You can then dial the next phone number.

The FLASH button also allows you to use special features of the host exchange (if connected) or local telephone company services such as call waiting. For further details, contact the supplier or your local telephone company.

PAUSE button

Pressing the REDIAL/PAUSE button causes a dialing delay in the dialing sequence.

Example-1: When your unit is connected to a host exchange, insert a pause as follows to get an outside line.

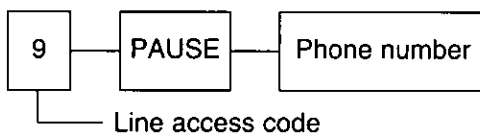

Example-2: If a transmission error occurs frequently when making an overseas transmission, add two pauses at the end of the phone number.

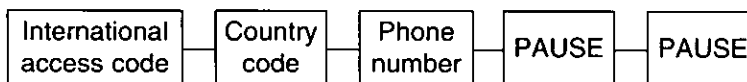

Note:

TONE, FLASH and PAUSE can be stored into a phone number for automatic dialing.

Printing reports and lists

You can print out the following reports/lists from your unit.

Feature List—provides you with the current settings of the basic and advanced programming features. (see page 60).

Telephone number list—provides you with phone numbers and their station names which are stored in automatic dialing.

(Code in each phone number)

P: A pause has been entered.

F: A flash has been entered.

[]: A secret phone number has been entered.
(The telephone number is not printed.)

Journal report—is useful for keeping records of fax transmissions and receptions. This report will be printed automatically after every 35 fax communications, but can be printed manually as shown below. You can change the setting of the journal auto print feature (see page 58).

Printer Test List—allows you to check the print quality of your unit. If the test print has a dirty pattern, or blurred points or lines, clean the thermal head (see page 67).

Transmission report—provides you a printed record of the fax transmission result. For further details, see page 58.

How to print each report/list

- 1 Press **MENU** until the following is displayed.

PRINT LIST

- 2 For the feature list, press **#**, then **1**.

SETUP LIST

For the telephone number list, press **#**, then **3**.

TEL NO. LIST

For the journal report, press **#**, then **4**.

JOURNAL REPORT

For the printer test list, press **#**, then **5**.

PRINTER TEST

- 3 Press **START/SET** to start printing.

PRINTING

•To interrupt printing, press **STOP**.

- 4 After printing, press **MENU**.

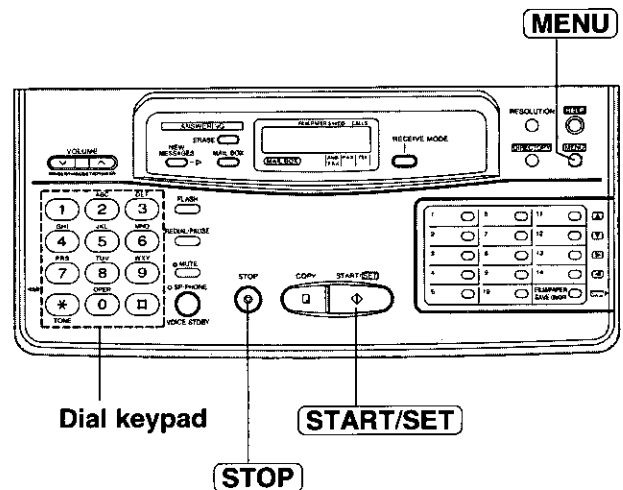

Setting the transmission report printing

One of the following choices is available.

ERROR: The transmission report will print out only when the fax transmission fails.

ON: The report will always print out, indicating whether fax transmission is successful or not.

OFF: The report will not print (pre-selected).

1 Press **MENU**.

SYSTEM SET UP

2 Press **#**, then **04**.

TX-REPORT MODE

3 Press **START/SET**.

MODE=OFF [▲▼]

4 Press ▲ or ▼ to select the desired mode.

5 Press **START/SET**.

6 Press **MENU**.

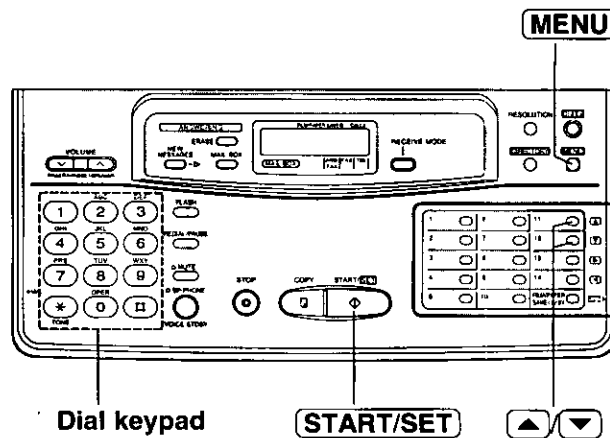

Setting journal auto print

The unit will automatically print a journal report after every 35 fax communications. After printing, the journal memory will be erased and only subsequent activity will be recorded.

When this feature is deactivated, the unit will store the records of the last 35 fax communications, but the unit will not print the journal report automatically.

1 Press **MENU**.

SYSTEM SET UP

2 Press **#**, then **22**.

AUTO JOURNAL

3 Press **START/SET**.

MODE=ON [▲▼]

4 Press ▲ or ▼ to select the desired mode.

5 Press **START/SET**.

6 Press **MENU**.

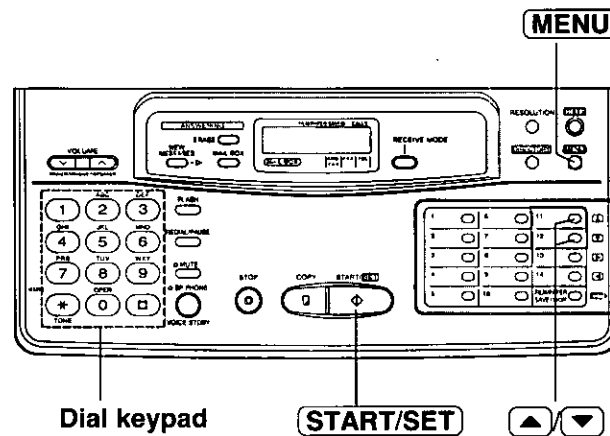

Sample of journal report

JOURNAL							
Jan. 25 1995 05:22PM							
NO.	OTHER FACSIMILE	START TIME	USAGE TIME	MODE	PAGES	RESULT	*CODE
01	1234567	Jan. 21 02:14PM	00'25	TX	01	OK	
02	9998765	Jan. 21 02:17PM	00'38	TX	02	OK	
03	<< G3 >>	Jan. 21 02:18PM	00'28	RX	01	OK	
04	555556677	Jan. 22 10:35AM	00'58	TX	03	COMMUNICATION ERROR	(43)
05			01'50	TX	05	OK	
				RX	03	OK	

Sample of transmission report

XMT REPORT							
Jan. 20 1995 01:19PM							
NO.	OTHER FACSIMILE	START TIME	USAGE TIME	MODE	PAGES	RESULT	*CODE
01	COMPANY ABC	Jan. 20 01:18PM	00'51	TX	00	COMMUNICATION ERROR	(43)

Communication
result (see below.)

Error code
(for service
personnel
use only)

Communication result on the report

When a problem has occurred, one of the following messages will be printed on the transmission report and the journal report.

PRINTED MESSAGE	MEANING
COMMUNICATION ERROR	A transmission or reception error occurred. Try again or check the other party.
DOCUMENT JAMMED	A document was jammed. Remove the jammed document (see page 66).
FILM EMPTY	Film is empty. Replace the film or film cartridge with a new one (see page 68).
JUNKMAIL PROH. REJECT	The junk mail prohibitor of your unit rejected fax reception (see page 35).
NO DOCUMENT	The document was not fed into the unit properly. Try again.
NO RESPONSE	The receiving unit was busy or ran out of recording paper. Try again.
PAPER JAMMED	The recording paper was jammed. Clear the jammed paper (see page 64).
PAPER OUT	Your unit ran out of recording paper. Install paper (see page 6).
PRESSED THE STOP KEY	The STOP button was pressed and fax communication was cancelled.
PRINTER OVERHEATED	Printer was overheated. Leave the unit to cool down.
THE COVER WAS OPENED	The top cover was open. Close it and try again.

Summary of user programmable features

Basic features

Code	Feature	Selection	Initial setting	Page
#01	SET DATE & TIME	mm/dd/yy hh:mm	(Jan./01/95 12:00AM)	12
#02	YOUR LOGO		(Panasonic FAX SYSTEM)	12
#03	YOUR TELEPHONE NUMBER			14
#04	PRINT TRANSMISSION REPORT	ERROR/ON/OFF	OFF	58
#07	FAX RING COUNT	1/2/3/4 rings	1 ring	21
#08	ANS/FAX RING COUNT	1/2/3/4/TOLL SAVER/RINGER OFF	1 ring	21
#09	RECORDING TIME	VOX/1 MIN	VOX	52
#10	REMOTE ANS ID		111	42

Advanced features

Code	Feature	Selection	Initial setting	Page
#21	LOGO POSITION	OUT/IN/OFF	OUT	46
#22	JOURNAL AUTO PRINT	ON/OFF	ON	58
#23	OVERSEAS MODE	ON/OFF	OFF	46
#24	JUNK MAIL PROHIBITOR	ON/OFF	OFF/ID=22	35
#25	DELAYED TRANSMISSION	ON/OFF	OFF	32
#31	RING DETECTION	OFF/A/B/C/D	OFF	36
#34	EXTENSION COPY			50
#35	COPY REDUCTION	92%/72%/OFF	OFF	47
#36	RX REDUCTION	92%/86%/72%/OFF	92%	48
#39	LCD CONTRAST	NORMAL/LIGHT/DARKER	NORMAL	55
#41	REMOTE FAX ACTIVATION CODE		**	34
#42	MESSAGE ALERT	ON/OFF	OFF	52
#43	RECORDING TIME ALERT	ON/OFF	OFF	53
#50	MAIL BOX ALERT	ON/OFF	OFF	53
#51	BOX1 PASSWORD		555	39
#52	BOX2 PASSWORD		555	39
#53	BOX3 PASSWORD		555	39
#60	COMMON PAGER	ON/OFF	OFF	54
#61	MAIL BOX1 PAGER	ON/OFF	OFF	54
#62	MAIL BOX2 PAGER	ON/OFF	OFF	54
#63	MAIL BOX3 PAGER	ON/OFF	OFF	54
#70	FAX PAGER	ON/OFF	OFF	51
#80	SET DEFAULT	YES/NO	NO	55

9. Troubleshooting and Routine Care

Error messages on the display

If the unit detects a problem, one of the following messages will appear on the display.

ERROR MESSAGE	CAUSE & REMEDY
BATTERY LOW	● Battery power is low. Replace the batteries with new ones (see page 5).
CHECK CASSETTE	● The recording paper is jammed near the paper cassette. Clear the jammed paper (see page 64).
CHECK COVER	● The top cover is open. Close it.
CHECK DOCUMENT	● The document is not fed into the unit properly. Reinsert the document and try again. If misfeeding occurs frequently, clean the feeder rollers (see page 67). If the problem remains, adjust the feeder pressure (see page 66).
CHECK FILM	● The film is not inserted in the cartridge correctly. Reinsert it correctly by referring to step 8 on page 69.
CHECK MEMORY	● Memory (phone numbers, parameters, etc.) has been erased. Re-program.
FILM EMPTY	● Film is empty. Replace the film or film cartridge with a new one (see page 68).
LOADING FILM	● The blue leader of the film was not wound completely or the unit was out of film. Wait for a while.
MEMORY FULL	● There is no room left in memory to record a message. Erase some or all messages (see page 24).
NO ANS GREETING	● The common greeting message has not been recorded. Record the message. (see page 15).
NO RESPONSE	● The receiving unit was busy or ran out of recording paper. Try again.
OUT OF PAPER	● The unit is out of recording paper. Install paper (see page 6).
PAPER JAMMED	● The recording paper is jammed near the head unit. Clear the jammed paper (see page 64).
POLLING ERROR	● The other fax machine does not provide the polling function. Check the other party.
REMOVE DOCUMENT	● The document is jammed. Remove the jammed document (see page 66). ● Attempted to transmit a document longer than 600 mm (23 $\frac{5}{8}$ "'). Press the STOP button and remove the document (see page 66). Divide it into two or more sheets and try again.
TRANSMIT ERROR	● Transmission error occurred. Try again.
UNIT OVERHEATED	● The unit is overheated. Leave it to cool down.

Before requesting help

General

PROBLEM	CAUSE & REMEDY
I cannot make and receive calls.	<ul style="list-style-type: none"> •The power cord or telephone line cord is not connected. Confirm the connection (see page 9).
I cannot make calls.	<ul style="list-style-type: none"> •The setting of the dialing mode is wrong. Check the selector (see page 9).
The unit does not work.	<ul style="list-style-type: none"> •Disconnect the unit from the telephone line and connect to a known working phone. If the known working phone operates properly, call your service personnel to have the unit repaired. If the known working phone does not operate properly, consult your telephone company.
The unit does not ring.	<ul style="list-style-type: none"> •The ringer volume is set to OFF. Raise it to a suitable level (see page 14).
The REDIAL/PAUSE button does not function properly.	<ul style="list-style-type: none"> •If this button is pressed during dialing, a pause will be inserted. If this button is pressed immediately after the dial tone is obtained, the last number dialed will be redialed.
While programming, I cannot enter the activation code or the prohibitor ID.	<ul style="list-style-type: none"> •The whole or part of the number is same as the other code or ID. Change the number (see pages 34, 35 and 42).

Fax Transmission & Reception

PROBLEM	CAUSE & REMEDY
The other party complains that letters on their received document are distorted.	<ul style="list-style-type: none"> •If your line has special telephone services such as call waiting, the service may have been activated during the fax transmission. Connect the unit to a line that does not have such services. •Another telephone connected to the same line is off the hook. Hang up and try again.
The other party complains that a dirty pattern or a black line appears on their received documents.	<ul style="list-style-type: none"> •The glass or rollers are dirty. Clean them (see page 67).
I cannot make an international fax call.	<ul style="list-style-type: none"> •Use the overseas transmission mode (see page 46). •Add two pauses at the end of the phone number (see page 56).
I cannot receive documents automatically.	<ul style="list-style-type: none"> •The receive mode is set to TEL. Set the receive mode to ANS/FAX or FAX. •The time to answer the call may be too long. Decrease the number of rings (see page 21). •The greeting message may be too long. Shorten the message or ask the other party to press * * and then start transmission.

PROBLEM	CAUSE & REMEDY
Recording image is faint.	<ul style="list-style-type: none"> •The sender transmitted a faint document. Request them to transmit a clearer copy of the document. •The thermal head is dirty. Clean it (see page 67).
A blank sheet is ejected after the received documents are printed out.	<ul style="list-style-type: none"> •The receiving reduction rate is not programmed correctly. Program the proper reduction rate (see page 48).

Answering Device

PROBLEM	CAUSE & REMEDY
No voice messages have been recorded in the ANS/FAX mode.	<ul style="list-style-type: none"> •The memory is full. Erase some or all messages (see page 24).
I cannot retrieve recorded messages from a remote phone.	<ul style="list-style-type: none"> •Make sure that you use the remote ANS ID correctly (see page 42). When you dial it, press the button firmly.
Messages in the mailbox do not play back.	<ul style="list-style-type: none"> •You have programmed the mailbox password. Press the password and then try again (see page 39).

Copying

PROBLEM	CAUSE & REMEDY
A dirty pattern or black line appears on the copied documents.	<ul style="list-style-type: none"> •The glass or rollers are dirty. Clean them (see page 67).
Copied image is distorted.	<ul style="list-style-type: none"> •The thermal head is dirty. Clean it (see page 67).
The document is not copied properly.	<ul style="list-style-type: none"> •The film is not inserted correctly. Insert it correctly (see page 68).
A paper jam occurs during copying.	<ul style="list-style-type: none"> •The film is not inserted correctly. Insert it correctly (see page 68).

Clearing a recording paper jam

If a recording paper jams, the display will show one of two messages below. Remove the jammed recording paper following either message.

PAPER JAMMED

A recording paper jammed near the head unit.

CHECK CASSETTE

A recording paper jammed near the paper cassette.

Removing a jammed recording paper near the head unit

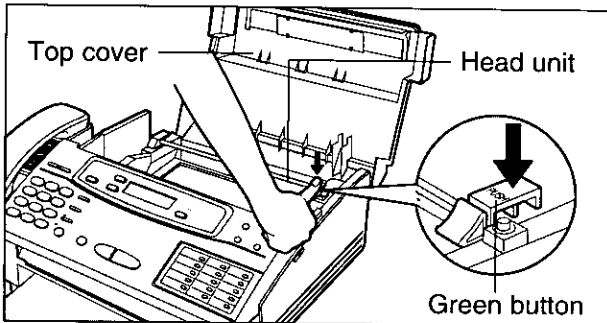

- 1 Open the top cover.
- 2 Press the green button on the right marked "PUSH" and lift up the head unit.

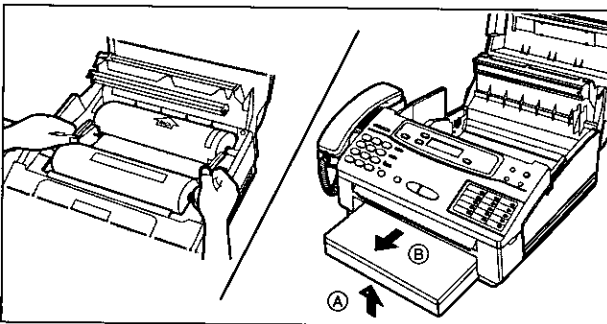

- 3 Remove the film cartridge.
- 4 Lift up the paper cassette slightly (A) and pull it towards you to remove it (B).

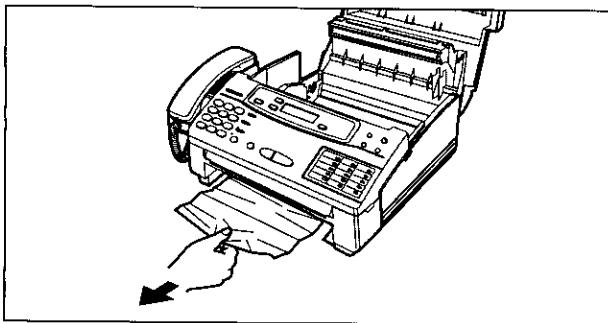

- 5 Remove the jammed recording paper.
 - If the jammed paper cannot be removed by the way of the illustration to the left, then remove it as below:

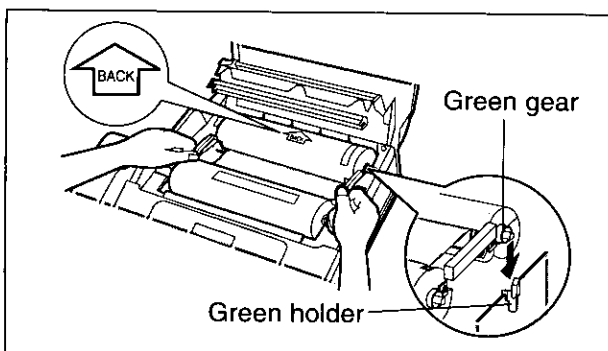
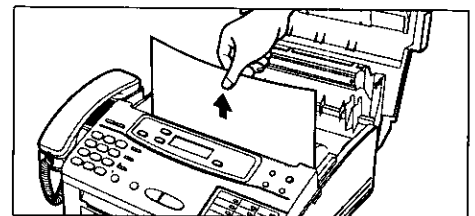

- 6 Place the "BACK" side of the cartridge into the unit, by inserting the pins on the sides of the green gears into the green holders. Then lower the front of the cartridge into place.
 - If the film is slack, tighten it by winding the gears.

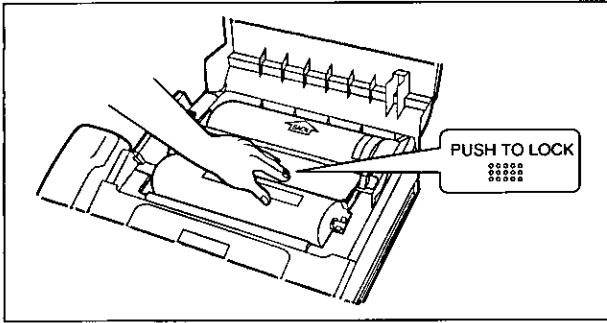

7 Press the head unit down firmly until it clicks into place.

8 Close the top cover securely by pushing down on both sides.

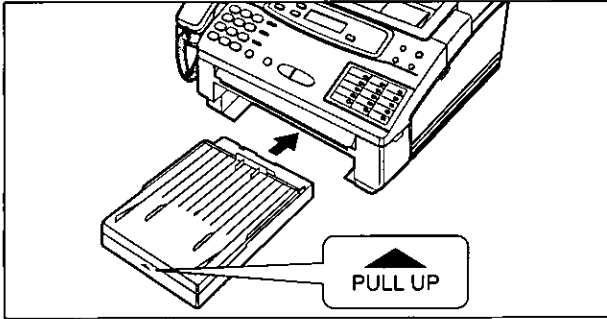

9 Insert the paper cassette into the unit until it clicks into place.

Removing a jammed recording paper near the paper cassette

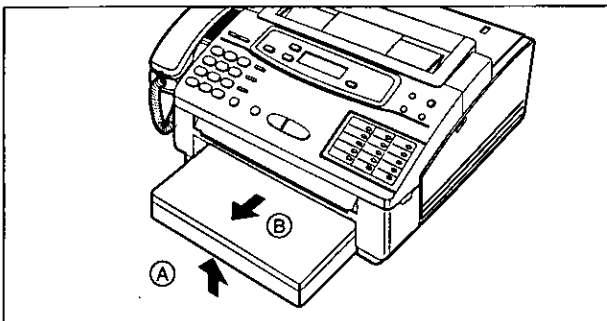

1 Lift up the paper cassette slightly (A) and pull it towards you to remove it (B).

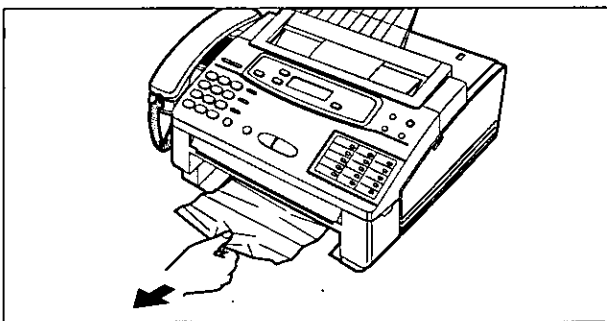

2 Reach into the paper cassette opening and remove the jammed recording paper.

- When the jammed paper cannot be removed easily, open the top cover and head unit, and remove the jammed paper. Do not pull the jammed paper forcibly, or torn pieces of paper may remain in the unit.

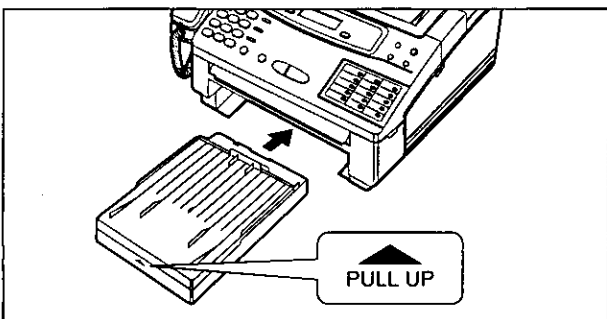

3 Insert the paper cassette into the unit until it clicks into place.

Clearing a document jam

If the unit does not release an original document during feeding, remove it as shown below.

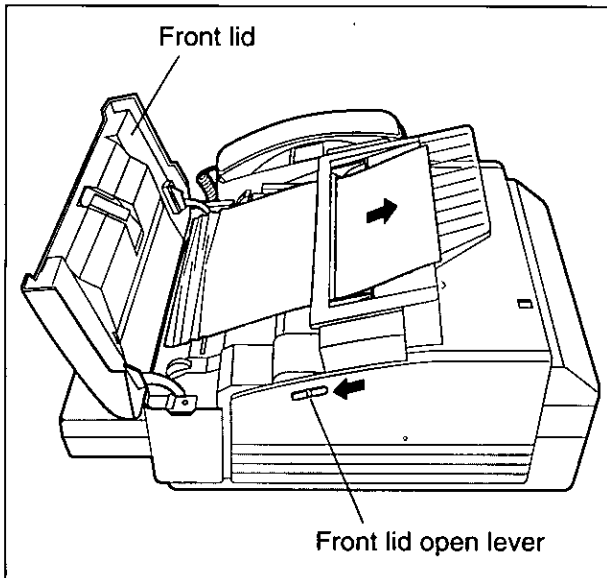

- 1 Slide the front lid open lever towards you to open the front lid.
- 2 Remove the jammed document carefully.
- 3 Close the lid securely by pushing down on both sides.

Adjusting the feeder pressure

If misfeeding of documents occurs frequently, adjust the feeder pressure.

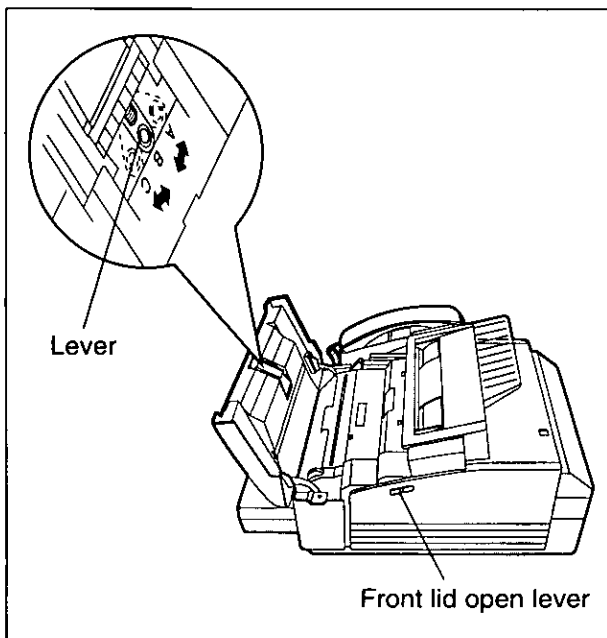

- 1 Slide the front lid open lever towards you to open the front lid.
- 2 Shift the position of the lever to a desired position by using an instrument with a pointed end, like a clip or ball-point pen.

Position A: No feeding
Position B: Standard position
Position C: Multiple feeding
- 3 Close the lid securely by pushing down on both sides.

Cleaning the unit

Cleaning the document feeder unit

If misfeeding occurs frequently or dirty patterns or black bands appear on a copied or transmitted document, clean the feeder rollers, sub roller, rubber flap, white plate and glass.

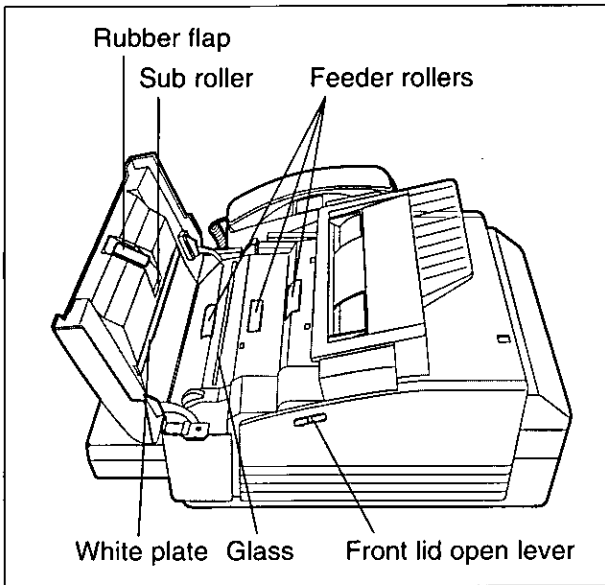

- 1 Disconnect the power cord and the telephone line cord.
- 2 Slide the front lid open lever towards you to open the front lid.
- 3 Clean the feeder rollers, sub roller and rubber flap with a cloth moistened with isopropyl rubbing alcohol, and let dry thoroughly.
- 4 Clean the white plate and the glass with a dry soft cloth.
- 5 Close the lid securely by pushing down on both sides.
- 6 Connect the power cord and telephone line cord.

Cleaning the thermal head

If dirty patterns or black bands appear on a copied or received document, clean the thermal head.

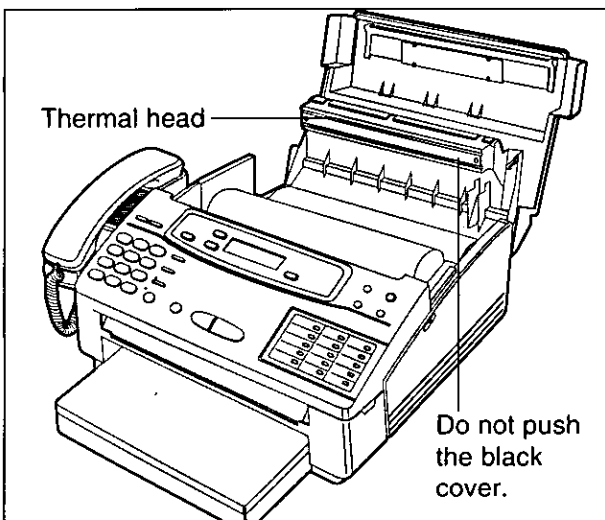

- 1 Disconnect the power cord and the telephone line cord.
- 2 Open the top cover.
- 3 Press the green button on the right marked "PUSH" and lift up the head unit.
- 4 Clean the thermal head with a cloth moistened with isopropyl rubbing alcohol, and let dry thoroughly.
- 5 Press the head unit down firmly until it clicks into place.
- 6 Close the top cover securely by pushing down on both sides.
- 7 Connect the power cord and telephone line cord.

Caution:

To prevent a malfunction due to static electricity, do not use a dry cloth and do not touch the thermal head directly with your finger.

Replacing the film or film cartridge

When the unit detects the end of the film, the following message will be displayed.

FILM EMPTY

Replace the film or film cartridge with a new one. To order a replacement part, see page 75.

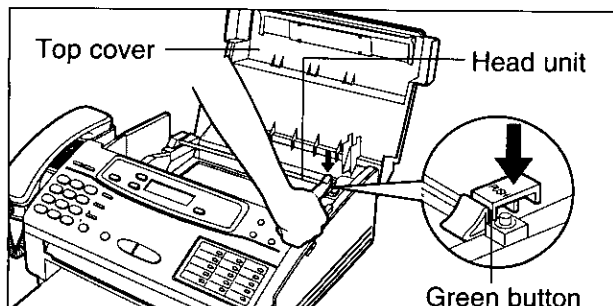

- 1 Open the top cover.
- 2 Press the green button on the right marked "PUSH" and lift up the head unit.

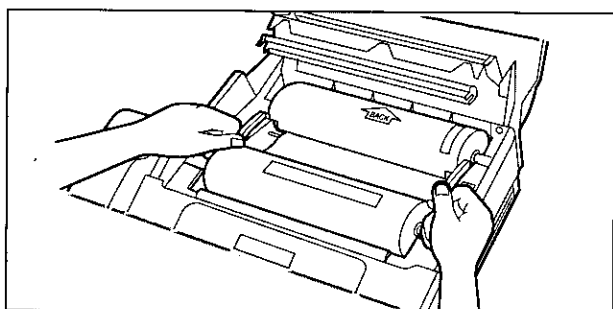

- 3 Take out the film cartridge.
 - If you purchased a film cartridge (Model no. KX-FA132) for replacement, skip to step 11.
 - To replace only the film, go to step 4.

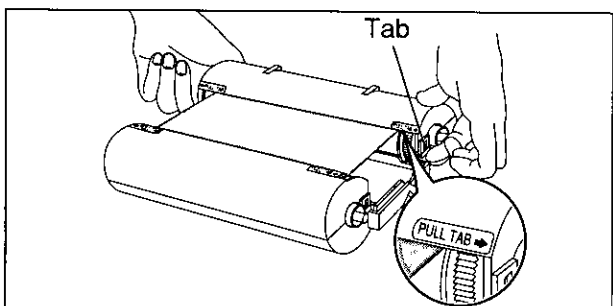

- 4 Turn over the cartridge so that the "PULL TAB" mark is facing up.
- 5 Unlock the four tabs of the cartridge, open the cover of the cartridge and take out the used film.

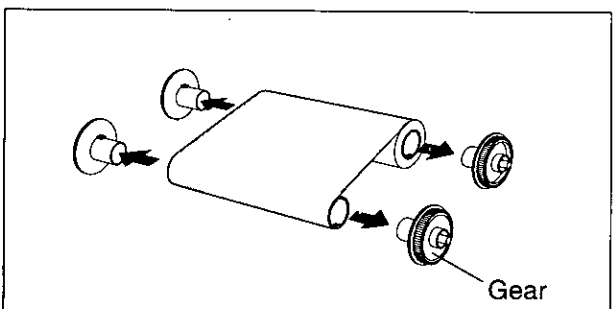

- 6 Pull out the four gears from the used film cores.

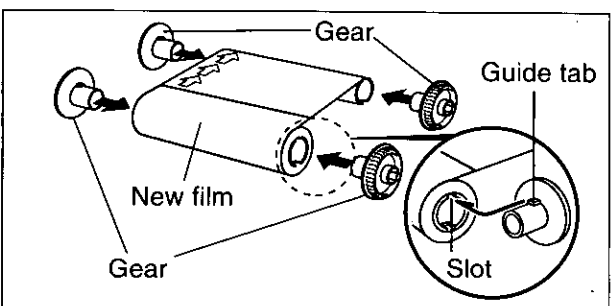

- 7 Insert the four gears into the new film cores so that the guide tab of each gear fits into the slot of the film core.

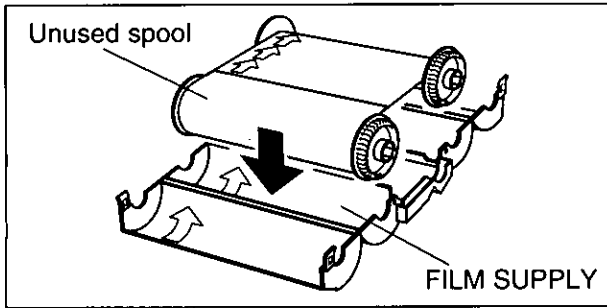

- 8** Insert the film into the cartridge so that the arrow on the open cartridge points in the same direction as the arrows on the film.
- If you insert a film which was used halfway, insert the unused spool of the film on the "FILM SUPPLY" mark of the cartridge.

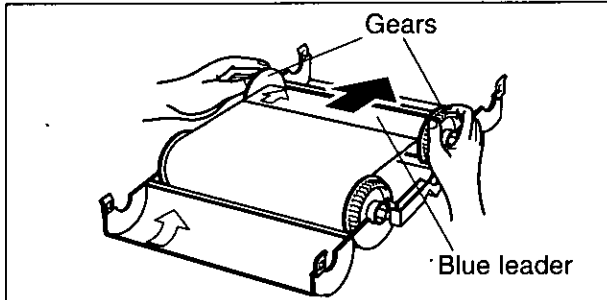
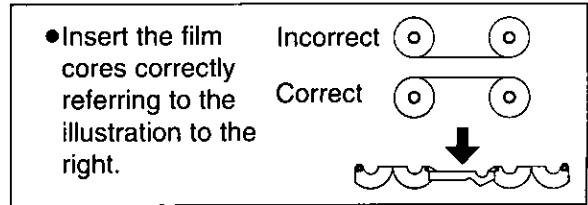

- 9** Roll the blue leader of the film by winding the gears of the core until the leader is no longer visible.

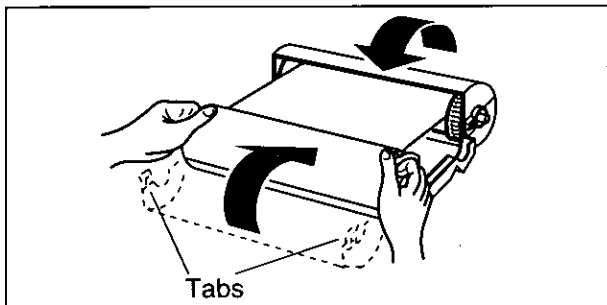

- 10** Close the covers of the cartridge by locking the four tabs.

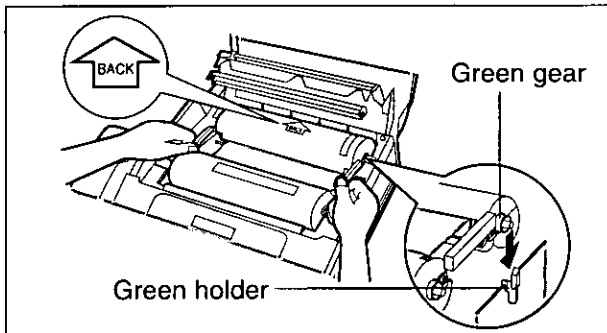

- 11** Turn over the cartridge and referring to the illustration on the left, place the "BACK" side of the cartridge into the unit, by inserting the pins on the sides of the green gears into the green holders. Then lower the front of the cartridge into place.

- 12** Press the head unit down firmly until it clicks into place.

- 13** Close the top cover securely by pushing down on both sides.
- If the blue leader of the film is not wound completely, the unit will automatically advance it and the following message will be displayed.

LOADING FILM

- If the following message is displayed, the film is not inserted in the cartridge correctly.

CHECK FILM

Reinsert it correctly by referring to step 8 on this page.

10. General Information

Important safety instructions

When using this product, basic safety precautions should always be followed to reduce the risk of fire, electric shock, and injury to persons, including the following:

1. Read and understand all instructions.
2. Follow all warnings and instructions marked on this product.
3. Unplug this product from wall outlets before cleaning. Do not use liquid or aerosol cleaners. Use a damp cloth for cleaning.
4. Do not use this product near water, for example, near a bath tub, wash bowl, kitchen sink, or laundry tub, in a wet basement, or near a swimming pool.
5. Do not place this product on an unstable cart, stand or table. The product may fall, causing serious damage to the product.
6. Slots and openings in the cabinet and the back or bottom are provided for ventilation, to protect it from overheating, these openings must not be blocked or covered. The openings should never be blocked by placing the product on the bed, sofa rug, or other similar surface. This product should never be placed near or over a radiator or heat register. This product should not be placed in a built-in installation unless proper ventilation is provided.
7. This product should be operated only from the type of power source indicated on the marking label. If you are not sure of the type of power supply to your home, consult your dealer or local power company.
8. This product is equipped with a three wire grounding type plug, a plug having a third (grounding) pin. This plug will only fit into a grounding type power outlet. This is a safety feature. If you are unable to insert the plug into the outlet, contact your electrician to replace your obsolete outlet. Do not defeat the safety purpose of the grounding type plug.
9. Do not allow anything to rest on the power cord. Do not locate this product where the cord will be abused by people walking on it.
10. Do not overload wall outlets and extension cords as this can result in the risk of fire or electric shock.
11. Never push objects of any kind into this product through cabinet slots as they may touch dangerous voltage points or short out parts that could result in a risk of fire or electric shock. Never spill liquid of any kind on the product.
12. To reduce the risk of electric shock, do not disassemble this product, but take it to a qualified serviceman when some service or repair work is required. Opening or removing covers may expose you to dangerous voltages or other risks. Incorrect reassembly can cause electric shock when the appliance is subsequently used.
13. Unplug this product from the wall outlet and refer servicing to qualified service personnel under the following conditions:
 - A. When the power supply cord or plug is damaged or frayed.
 - B. If liquid has been spilled into the product.
 - C. If the product has been exposed to rain or water.
 - D. If the product does not work normally by following the operating instructions. Adjust only those controls, that are covered by the operating instructions because improper adjustment of other controls may result in damage and will often require extensive work by a qualified technician to restore the product to normal operation.
 - E. If the product has been dropped or the cabinet has been damaged.
 - F. If the product exhibits a distinct change in performance.
14. Avoid using a telephone (other than a cordless type) during an electrical storm. There may be a remote risk of electric shock from lightning.
15. Do not use the telephone to report a gas leak in the vicinity of the leak.

SAVE THESE INSTRUCTIONS

CAUTION:

To reduce the risk of fire or injury to persons, read and follow these instructions.

1. Use only the battery(ies) instructed.
2. Do not dispose of the battery(ies) in a fire. The cell may explode. Check with local codes for possible special disposal instructions.
3. Do not open or mutilate the battery(ies). Released electrolyte is corrosive and may cause damage to the eyes or skin. It may be toxic if swallowed.
4. Exercise care in handling batteries in order not to short the battery with conducting materials such as rings, bracelets, and keys. The battery or conductor may overheat and cause burns.
5. Do not attempt to recharge the battery(ies) provided with or identified for use with this product. The batteries may leak corrosive electrolyte or explode.
6. Do not attempt to rejuvenate the battery(ies) provided with or identified for use with this product by heating them. Sudden release of the battery electrolyte may occur causing burns or irritation to eyes or skin.
7. When replacing batteries, all batteries should be replaced at the same time. Mixing fresh and discharged batteries could increase internal cell pressure and rupture the discharged battery(ies). (Applies to products employing more than one separately replaceable primary battery.)
8. When inserting batteries into this product, the proper polarity or direction must be observed. Reverse insertion of batteries can cause charging, and that may result in leakage or explosion. (Applies to product employing more than one separately replaceable primary battery.)
9. Remove the batteries from this product if the product will not be used for a long period of time (several months or more) since during this time the battery could leak in the product.
10. Discard "dead" batteries as soon as possible since "dead" batteries are more likely to leak in a product.

11. Do not store this product, or the batteries provided with or identified for use with this product, in high-temperature areas. Batteries that are stored in a freezer or refrigerator for the purpose of extending shelf life should be protected from condensation during storage and defrosting. Batteries should be stabilized at room temperature prior to use after cold storage.

INSTALLATION:

1. Never install telephone wiring during a lightning storm.
2. Never install telephone jacks in wet locations unless the jack is specifically designed for wet locations.
3. Never touch uninsulated telephone wires or terminals unless the telephone line has been disconnected at the network interface.
4. Use caution when installing or modifying telephone lines.

WARNING:

To prevent the risk of fire or electrical shock, do not expose this product to rain or any type of moisture.

OTHER INFORMATION

- Keep the unit away from electrical noise-generating devices, such as fluorescent lamps and motors.
- The unit should be kept free from dust, moisture, high temperature, and vibration.
- The unit should not be exposed to direct sunlight.
- Do not place heavy objects on top of this unit.
- Do not damage the power cord.
- Do not touch the plug with wet hands.
- Do not use benzine, thinner, or any abrasive powder, to clean the cabinet. Wipe it with a soft cloth.
- Do not mix different types of batteries.
- Do not use Nickel-Cadmium batteries.

FCC information

If required by the telephone company, inform them of the following.

- FCC Registration No.: (found on the rear side of the unit)
- Ringer Equivalence No.: (found on the rear side of the unit)
- The particular telephone line to which the equipment is connected.

This unit must not be connected to a coin operated line. If you are on a party line, check with your local telephone company.

Ringer Equivalence Number (REN):

This REN is useful in determining the quantity of devices you may connect to your telephone line and still have all of those devices ring when your telephone number is called. In most but not all areas, the sum of the REN's of all devices connected to one line should not exceed five (5.0). To be certain of the number of devices you may connect to your line, as determined by the REN, you should contact your local telephone company to determine the maximum REN for your calling area.

In the event that terminal equipment causes harm to the telephone network, the telephone company should notify the customer, if possible, that service may be stopped. However, where prior notice is impractical, the company may temporarily cease service providing that they:

- a) Promptly notify the customer.
- b) Give the customer an opportunity to correct the problem with their equipment.
- c) Inform the customer of the right to bring a complaint to the Federal Communication Commission pursuant to procedures set out in FCC Rules and Regulations Subpart E of Part 68.

The Telephone Company may make changes in its communications facilities, equipment operations, or procedures where such action is reasonably required in the operation of its business and is not inconsistent with the rules and regulations in FCC Part 68. If such changes can be reasonably expected to render any customer terminal equipment incompatible with telephone company communications facilities, or require modification or alteration of such terminal equipment, or otherwise materially affect its use or performance, the customer shall be given adequate notice in

writing, to allow the customer an opportunity to maintain uninterrupted service.

CAUTION:

Any changes or modifications not expressly approved by the party responsible for compliance could void the user's authority to operate this device.

When programming emergency numbers and/or making test calls to emergency numbers:

1. Remain on the line and briefly explain to the dispatcher the reason for the call before hanging up.
2. Perform such activities in the off-peak hours; such as early morning or late evenings.

This telephone provides magnetic coupling to hearing aids.

NOTE:

This equipment has been tested and found to comply with the limits for a Class B digital device, pursuant to Part 15 of the FCC Rules. These limits are designed to provide reasonable protection against harmful interference in a residential installation. This equipment generates, uses, and can radiate radio frequency energy and, if not installed and used in accordance with the instructions, may cause harmful interference to radio communications. However, there is no guarantee that interference will not occur in a particular installation. If this equipment does cause harmful interference to radio or television reception, which can be determined by turning the equipment off and on, the user is encouraged to try to correct the interference by one or more of the following measures:

- Reorient or relocate the receiving antenna.
- Increase the separation between the equipment and receiver.
- Connect the equipment into an outlet on a circuit different from that to which the receiver is connected.
- Consult the dealer or an experienced radio/TV technician for help.

Limited warranty

Matsushita Consumer Electronics Company or Panasonic Sales Company (collectively referred to as The warrantor), will repair this product with new or refurbished parts, free of charge, in the U.S.A. or Puerto Rico for one (1) year from the date of original purchase in the event of a defect in materials or workmanship.

Batteries (when applicable) —New rechargeable batteries in exchange for defective rechargeable batteries for ten (10) days from the date of original purchase. Non-rechargeable batteries are not warranted.

Carry-in or mail-in service in the U.S.A. can be obtained during the warranty period from a Matsushita Services Company (MSC) Factory Servicenter listed in the Servicenter Directory. Carry-in or mail-in service in Puerto Rico can be obtained during the warranty period by calling the telephone numbers listed in the Servicenter Directory.

This warranty is extended only to the original purchaser. A purchase receipt or other proof of date of original purchase will be required before warranty performance is rendered.

This warranty only covers failures due to defects in materials or workmanship which occur during normal use. It does not cover damage which occurs in shipment or failures which are caused by products not supplied by the warrantor or failures which result from accident, misuse, abuse, neglect, mishandling, misapplication, alteration, faulty installation, modification, or service by anyone other than an MSC Factory Servicenter or an authorized MSC Servicenter or damage that is attributable to Acts of God, including, but not limited to, line surges.

LIMITS AND EXCLUSIONS

There are no express warranties except as listed above.

THE WARRANTOR SHALL NOT BE LIABLE FOR SPECIAL, INCIDENTAL, CONSEQUENTIAL OR PUNITIVE DAMAGES, INCLUDING, WITHOUT LIMITATION, LOSS OF GOODWILL, PROFITS OR REVENUE, LOSS OF USE OF THIS PRODUCT OR ANY ASSOCIATED EQUIPMENT, COST OF SUBSTITUTE EQUIPMENT, DOWNTIME COSTS, OR CLAIMS OF ANY PARTY DEALING WITH BUYER FOR SUCH DAMAGES, RESULTING FROM THE USE OF THIS PRODUCT OR ARISING FROM BREACH OF WARRANTY OR CONTRACT, NEGLIGENCE, OR ANY OTHER LEGAL THEORY. ALL EXPRESS AND IMPLIED WARRANTIES, INCLUDING THE WARRANTIES OF MERCHANTABILITY AND FITNESS FOR A PARTICULAR PURPOSE, ARE LIMITED TO THE APPLICABLE WARRANTY PERIOD SET FORTH ABOVE.

Some states do not allow the exclusion or limitation of consequential damages, or limitations on how long an implied warranty lasts, so the above exclusions or limitations may not apply to you.

This warranty gives you specific legal rights, and you may also have other rights which vary from state to state.

If a problem with this product develops during the warranty period, you may contact your dealer or the MSC Factory Servicenter or authorized MSC servicenter. If the problem is not handled to your satisfaction, write to the Customer Satisfaction Center at the address indicated on the Servicenter Directory.

Service center directory

OPERATION ASSISTANCE • FAX ADVANTAGE PROGRAM

DIAL TOLL FREE: 1-800-HELP-FAX (9:00am–8:00pm Monday–Friday, EST)

PRODUCT INFORMATION • LITERATURE REQUESTS • DEALER LOCATIONS

Customer Satisfaction Center 2F-3, One Panasonic Way, Secaucus, NJ 07094 (Headquarters)
201-348-9090 (9:00am–8:00pm Monday–Friday, EST)

ACCESSORY PURCHASES

1-800-332-5368 (Consumer orders only)

Matsushita Services Company Accessory Order Office, 20421-84th Avenue South Kent, WA 98032
(6:00am–6:00pm Monday–Friday, 6:00am–10:30am Saturday, PST)
(Visa, Mastercard, Discover card, Check or Money Order)

AUTHORIZED SERVICENTERS

CALIFORNIA

6550 Katella Avenue
Cypress, CA 90630
Phone (714) 373-7425
Fax (714) 894-8534

800 Dubuque Avenue
S. San Francisco,
CA 94080
Phone (415) 871-6373
Fax (415) 871-6840

20201 Sherman Way
Suite 102
Canoga Park, CA 91306
Phone (818) 709-1775
Fax (818) 709-2165

3878 Ruffin Road
Suite A
San Diego, CA 92123
Phone (619) 560-9200
Fax (619) 560-1831

COLORADO

1640 South Abilene Suite D
Aurora, CO 80012
Phone (303) 752-2024
Fax (303) 752-0610

FLORIDA

3700 North 29th Avenue
Suite 102
Hollywood, FL 33020
Phone (305) 925-2880
Fax (305) 925-5224

4710 Eisenhower
Boulevard Suite A1
Tampa, FL 33634
Phone (813) 884-4746
Fax (813) 886-4564

GEORGIA

8655 Roswell Road
Suite 100
Atlanta, GA 30350
Phone (404) 518-6301
Fax (404) 518-6306

HAWAII

99-859 Iwaiwa Street
Aiea, Hawaii 96701
Phone (808) 488-1996
Fax (808) 486-4369

ILLINOIS

* 1703 North Randall Road
Elgin, IL 60123
"12:30 to 4:30, Mon-Fri"
Phone (708) 468-5466
Fax (708) 468-5465

9060 Golf Road
Niles, IL 60714
Phone (708) 299-1700
Fax (708) 299-1710

MARYLAND

Sulphur Springs
Business Park
1638 Sulphur Springs Road
Baltimore, MD 21227
Phone (410) 242-2607
Fax (410) 247-3047

MASSACHUSETTS

60 Glacier Drive, Suite G
Westwood, MA 02090
Phone (617) 329-4280
Fax (617) 329-0586

*pick-up/drop-off only

MICHIGAN

37048 Van Dyke Avenue
Sterling Heights, MI 48312
Phone (810) 939-2060
Fax (810) 939-2638

MINNESOTA

7850-12th Avenue South
Airport Business Center
Bloomington, MN 55425
Phone (612) 854-8624
Fax (612) 854-2089

MISSOURI

11982 Dorsett Road
Maryland Heights, MO 63043
Phone (314) 739-5301
Fax (314) 739-3631

OHIO

2236 Waycross Road
Cincinnati, OH 45240
Phone (513) 851-4180
Fax (513) 851-8443

PENNSYLVANIA

2221 Cabot Boulevard West
Suite B
Langhorne, PA 19047
Phone (215) 741-0661
Fax (215) 741-0521

Chartiers Valley
Shopping Center
1025 Washington Pike
Bridgeville, PA 15017
Phone (412) 257-4522
Fax (412) 257-4650

TENNESSEE

919-8th Avenue South
Nashville, TN 37203
Phone (615) 244-4434
Fax (615) 244-6713

TEXAS

7482 Harwin Drive
Houston, TX 77036
Phone (713) 781-1528
Fax (713) 781-0643

13615 Welch Road Suite 101
Farmers Branch, TX 75244
Phone (214) 385-1975
Fax (214) 960-7626

WASHINGTON

20425-84th Avenue South
Kent, WA 98032
Phone (206) 872-7922
Fax (206) 872-0918

Service in Puerto Rico

**Matsushita Electric
of Puerto Rico, Inc.
Panasonic Sales Company/
Factory Servicer**

Ave. 65 de Infantería, Km. 9.5
San Gabriel Industrial Park
Carolina, Puerto Rico 00985
Phone (809) 750-4300
Fax (809) 768-2910

REPAIR INQUIRIES

Regional Customer Care Department

EAST (PCE)

2221 Cabot Boulevard West
Suite A
Langhorne, PA 19047
Phone (215) 741-0676
Fax (215) 750-6492

Covers:

CT, DE, ME, MD, MA, NH, NJ,
NY, PA, RI, VT, VA, DC, WV

EAST (PCE)

1225 Northbrook Parkway
Suite 2-390
Suwanee, GA 30174
Phone (404) 338-6860
Fax (404) 338-6548

Covers:

AL, FL, GA, MS, NC, SC, TN

CENTRAL (PCC)

1703 North Randall Road
Elgin, IL 60123
Phone (708) 468-5530
Fax (708) 468-5528

Covers:

AR, IL, IN, IA, KS, KY, LA, MI,
MN, MO, NE, ND, OK, SD, TX,
WI, OH

WEST (PCW)

6550 Katella Avenue
Cypress, CA 90630
Phone (714) 373-7440
Fax (714) 373-7447

Covers:

AK, AZ, CA, CO, ID, MT, NV,
NM, OR, UT, WA, WY, HI

PARTS DISTRIBUTION LOCATIONS

To locate parts distributors in your area (within the USA)
DIAL TOLL FREE 1-800-545-2672 (24 hours a day, 7 days a week)

(950807)

Accessory order information

Use the following for replacement. For accessory order, call toll free 1-800-332-5368. Problems will occur if other brands of films are used.

Model No.	Description	Comment
KX-FA132	Film cartridge	1 cartridge & film: 216 mm×200 m (8½"×656') roll
KX-FA133	Replacement film (1 set)	216 mm×200 m (8½"×656') roll
KX-FA134	Replacement film (2 sets)	216 mm×200 m (8½"×656') roll

Specifications

- | | |
|------------------------------|--|
| 1. Applicable Lines: | Public Switched Telephone Network |
| 2. Document Size: | Max. 216 mm (8½") in width
Max. 600 mm (23⅝") in length |
| 3. Effective Scanning Width: | 208 mm (8⅜") |
| 4. Recording Paper Size: | Letter: 216×279 mm (8½"×11")
Legal: 216×356 mm (8½"×14") |
| 5. Effective Printing Width: | 208 mm (8⅜") |
| 6. Transmission Time*: | Approx. 15 sec./page (Original mode)
Approx. 30 sec./page (G3 Normal mode) |
| 7. Fax Auto Redial: | Up to 5 times |
| 8. Telephone Auto Redial: | Up to 14 times |
| 9. Scanning Density: | Horizontal: 8 pels/mm (203 pels/inch)
Vertical: 3.85 lines/mm (98 lines/inch)—Standard
7.7 lines/mm (196 lines/inch)—Fine/Halftone |
| 10. Halftone Level: | 64-level |
| 11. Scanner Type: | CCD Image Sensor |
| 12. Printer Type: | Thermal Transfer |
| 13. Data Compression System: | Modified Huffman (MH), Modified READ (MR) |
| 14. Modem Speed: | 9600/7200/4800/2400 bps; Automatic Fallback |
| 15. Operating Environment: | 5–35°C (41–95°F), 20–80 % RH |
| 16. Dimensions (H×W×D): | 237×420×389 mm (9⅝"×16⅞"×15⅝") |
| 17. Mass (Weight): | Approx. 9.0 kg (19.8 lb.) |
| 18. Power Consumption: | Transmission: Approx. 17 W / Reception: Approx. 40 W
Copy: Approx. 50 W / Standby: Approx. 5 W
Maximum: Approx. 140 W |
| 19. Power Supply: | 120 V AC, 60 Hz |

*Transmission Time: Transmission times apply to text data using the CCITT No. 1 test chart, between the same machine models at maximum modem speed. The transmission time does not include call setup, ringing, handshaking and sign off. Transmission times may vary.

Note:

- Any details given in these instructions are subject to change without notice.
- The picture and illustrations in these instructions may vary slightly from the actual product.

Information for users

For product service

- Service centers are listed on page 74.
- Call toll free 1-800-545-2672 for the location of an authorized service center.

When you ship the product

- Carefully pack your unit, preferably in the original carton.
- Attach a letter, detailing the symptom, to the outside of the carton.

Symptom

- Send the unit to an authorized service center, prepaid and adequately insured.
- Do not send your unit to the Matsushita Consumer Electronics Company on back cover page or to any executive or regional sales offices. These locations do not repair consumer products.

Fax Correspondence

To: _____ Date: _____

From: _____ Our Tel No.: _____

We would like to take this opportunity to introduce you to our Panasonic telephone answering device with facsimile. Our unit will work as a facsimile, an answering device and a standard telephone, so you can send both documents and voice messages on the same call.

Leaving a voice message and transmitting a document

1. Dial our phone number.
 - Our unit will play the greeting message.
2. Leave your message after the long beep.
3. Press your “*” (asterisk) button **twice** to activate the fax.
 - A fax tone will sound.
4. Start transmission to send a fax.

Transmitting a document only

1. Dial our phone number.
 - Our unit will play the greeting message.
2. Press your “*” button **twice** while the greeting message is being played.
 - A fax tone will sound.
3. Start transmission to send a fax.

Leaving a voice message and transmitting a document from a rotary (pulse) phone

1. Dial our phone number.
 - Our unit will play the greeting message.
2. Start transmission to send a fax.
3. Make voice contact (e.g. ...lift the handset) during transmission of your document.
4. Leave your message after the long beep following the greeting message.

Transmitting a document from a rotary (pulse) phone

1. Dial our phone number.
 - Our unit will play the greeting message.
2. Start transmission to send a fax while the greeting message is being played.

----- Detach here and transmit this sheet FACE DOWN. -----

Note for the customer of this unit:

To receive voice messages and documents automatically, set the unit in the ANS/FAX mode.

Speed dialer list

Station No.	Name/Phone No.	Station No.	Name/Phone No.
00		30	
01		31	
02		32	
03		33	
04		34	
05		35	
06		36	
07		37	
08		38	
09		39	
10		40	
11		41	
12		42	
13		43	
14		44	
15		45	
16		46	
17		47	
18		48	
19		49	
20		50	
21		51	
22		52	
23		53	
24		54	
25		55	
26		56	
27		57	
28		58	
29		59	

Speed dialer list

Station No.	Name/Phone No.	Station No.	Name/Phone No.
00		30	
01		31	
02		32	
03		33	
04		34	
05		35	
06		36	
07		37	
08		38	
09		39	
10		40	
11		41	
12		42	
13		43	
14		44	
15		45	
16		46	
17		47	
18		48	
19		49	
20		50	
21		51	
22		52	
23		53	
24		54	
25		55	
26		56	
27		57	
28		58	
29		59	

<p style="text-align: center;">Mailbox Remote Operation</p> <p>■ Recording a message into a mailbox:</p> <ol style="list-style-type: none">1. Call your unit.2. Press * and the mailbox no. (1, 2 or 3).3. Leave a message. <p>■ Retrieving messages from a mailbox:</p> <ol style="list-style-type: none">1. Call your unit.2. Press * and the mailbox no. (1, 2 or 3).3. Press the mailbox password <input type="text"/> <input type="text"/> <input type="text"/>.4. Press the remote command key (refer to the reverse side).	<p style="text-align: center;">Mailbox Remote Operation</p> <p>■ Recording a message into a mailbox:</p> <ol style="list-style-type: none">1. Call your unit.2. Press * and the mailbox no. (1, 2 or 3).3. Leave a message. <p>■ Retrieving messages from a mailbox:</p> <ol style="list-style-type: none">1. Call your unit.2. Press * and the mailbox no. (1, 2 or 3).3. Press the mailbox password <input type="text"/> <input type="text"/> <input type="text"/>.4. Press the remote command key (refer to the reverse side).
<p style="text-align: center;">Mailbox Remote Operation</p> <p>■ Recording a message into a mailbox:</p> <ol style="list-style-type: none">1. Call your unit.2. Press * and the mailbox no. (1, 2 or 3).3. Leave a message. <p>■ Retrieving messages from a mailbox:</p> <ol style="list-style-type: none">1. Call your unit.2. Press * and the mailbox no. (1, 2 or 3).3. Press the mailbox password <input type="text"/> <input type="text"/> <input type="text"/>.4. Press the remote command key (refer to the reverse side).	<p style="text-align: center;">Notice of Remote Operation</p> <ul style="list-style-type: none">● The remote operation is available only from a touch tone phone when the unit is in the <i>ANS/FAX</i> mode.● When the unit is in the <i>TEL</i> mode, call your unit and wait for 15 rings. The unit will switch to <i>ANS/FAX</i> mode.● When you press any key, press firmly.● To send a document, press ***. When a fax tone is heard, start transmission.

Fold here

Key	Remote Command
1	Repeating a message
2	Skipping a message
4	New message playback
5	All message playback
6	Room monitoring
7	Re-recording a greeting message
9	Stopping re-recording of a greeting message
*4	Erasing a specific message
*5	Erasing all messages
8 1	Pager alert for ANS—ON
8 2	Pager alert for ANS—OFF

Key	Remote Command
1	Repeating a message
2	Skipping a message
4	New message playback
5	All message playback
6	Room monitoring
7	Re-recording a greeting message
9	Stopping re-recording of a greeting message
*4	Erasing a specific message
*5	Erasing all messages
8 1	Pager alert for ANS—ON
8 2	Pager alert for ANS—OFF

Answering Device Remote Operation

1. Call your unit.
2. Press the remote ANS ID during the greeting message.
3. Press remote command key (refer to right) within 4 seconds.
or
Wait for 4 seconds. All the recorded messages will be played back.

- To skip the greeting message, press **0**.
- To erase a specific message, press ***4** when a message to be erased is being played back.
- To erase all the recorded messages, press ***5**.

Key	Remote Command
1	Repeating a message
2	Skipping a message
4	New message playback
5	All message playback
6	Room monitoring
7	Re-recording a greeting message
9	Stopping re-recording of a greeting message
*4	Erasing a specific message
*5	Erasing all messages
8 1	Pager alert for ANS—ON
8 2	Pager alert for ANS—OFF

Index

A	ALL MESSAGES button	23	Message alert	52	
	ANS/FAX mode	16, 20	MUTE button	17	
	ANS/FAX ring count	21			
	Answering device volume	14	N	NEW MESSAGES button	23
	Automatic dialing	27, 28			
C	CHECK button	15, 38	O	One-touch dialing	27, 28
	Cleaning	67		Overseas transmission mode	46
	COPY button	26, 50	P	Pager alert for incoming messages	54
	Copy reduction mode	47		Pager alert for fax reception	51
D	Date and time	12		PAUSE button	56
	Delayed transmission	32		Polling	31
	DELETE key	13	R	REC button	15, 38
	Dialing mode	9		RECEIVE MODE button	16
	Direct call station keys	13, 27, 28		Receiving reduction mode	48
	DIRECTORY button	28, 29		REDIAL/PAUSE button	17
	Display contrast	55		Remote ANS ID	42
E	Electronic telephone directory	29		Remote fax activation code	34
	ERASE button	24		REPEAT button	23
	Error messages	61		RESOLUTION button	18
	Extension copy	50		Ring pattern detection	36
F	FAX mode	16, 20		Ringer volume	14
	FAX ring count	21	S	SECRET key	27
	Feeder pressure	66		SELECT button	15
	FILM/PAPER SAVE key	49		Set default	55
	FLASH button	56		SKIP button	23
H	Handset volume	14		SPACE key	13
	HELP button	9		Speaker volume	14
I	INSERT key	13		Speed dialing	27, 28
J	Journal auto print	58		SP-PHONE button	17, 18
	Journal report	57, 59		START/SET button	12, 18
	Junk mail prohibitor	35		STOP button	18
L	Logo position	46	T	TEL mode	16
M	MAIL BOX button	40		Telephone number list	57
	Mailbox alert	53		TONE button	56
	Mailbox password	39		Transmission report	57, 58
	MEMO/2WAY REC button	24, 25	V	Voice contact	30
	MENU button	12, 27, 31, 57		VOICE STDBY button	30
				VOLUME button	14
			Y	Your logo	12
				Your facsimile telephone number	14

Panasonic FAX ADVANTAGE PROGRAM

We are proud to present the Panasonic Fax Advantage Program. It's an incredible service program that's full of exciting advantages!

Customer Satisfaction

In support of our one-year limited warranty* (parts and labor) on our current fax product line, Panasonic is proud to offer you the following service options during the limited warranty period:

- 1 If you mail-in or carry-in your fax unit to one of our Regional Servicenters, the product will be repaired and returned to you, or...
- 2 If you call our 1-800-HELPFAX toll-free number, you will receive a refurbished replacement product overnight or on the second business day (delivery depending on the time of your call.)

Support After The Sale

If you have a problem with your fax, just call our 1-800-HELPFAX toll-free number for friendly support and assistance. We have a highly-qualified team of experts who can diagnose, and most likely solve, your problem over the phone. Approximately 90% of our customers' problems are resolved with just a simple phone call.

The Fax Advantage Program covers the first year of purchase and works like this:

- 1 If you have a problem with your fax, call toll-free 1-800-HELPFAX.
- 2 Talk to one of our experienced technical experts to diagnose (and most likely solve) your problem over the phone.
- 3 Providing that you may be entitled to Panasonic's service under the terms and conditions of the limited warranty**, we will arrange for a reconditioned replacement unit to be shipped to you overnight or second business day delivery, depending on the time of your call. The replacement unit will be completely refurbished, quality-tested by Panasonic technicians, and individually hand-inspected before it is shipped to you. You will keep the replacement unit and send your original unit to us, along with a copy of your receipt.
- 4 This receipt must be shipped back with your original unit to Panasonic Company (as per instructions enclosed in your replacement unit's box).

Any unit that is replaced by Panasonic and not backed up by a proof of purchase by you will be subject to a minimum \$100.00 charge. Any unit that is replaced, but does not meet the terms and conditions of the limited warranty will be subject to additional charges, as per the program guidelines.

5 Once you receive your replacement unit, pack up your problem unit in the replacement unit's box. UPS will make 3 attempts within 10 days to pick-up your defective unit at no charge to you (should you be entitled to warranty service. If warranty conditions do not apply, you will be charged for all applicable shipping charges). The product must be properly packaged in the same manner as the replacement unit, utilizing the packing materials provided. You must make your unit available for UPS pick-up. If your unit is not available for UPS, you will be responsible for shipping unit back at your expense. Damage due to improper or inadequate packing will be charged back to your charge card as an out-of-warranty cost, as per the warranty stipulations.

Requirements:

6 You must give our technicians a valid credit card number. They will change your card account to cover any charges that are incurred by failure to send the problem product to Panasonic Company. If your problem unit is not eligible for warranty, you will be charged for the repair of the unit and for any shipping charges associated with this program. If you do not wish to pay out-of-warranty repair costs, you will be responsible for returning the replacement unit to Panasonic and for paying all shipping charges associated with this program including the overnight delivery of replacement product to you, shipment of problem unit to Panasonic, the replacement unit back to Panasonic and the return of your original unit back to you.

Acceptable credit cards:

Discover VISA
Master Card American Express (Optima)

Product that is not returned to Panasonic by 10 business days after shipment of the replacement product, will be charged to your account at Panasonic's Suggested Retail Price (see dealer for details).

Credit status will be verified prior to sending the replacement product.

Proof of Purchase must be included with the returned unit to verify warranty status.

Any parts and labor that are not covered by the limited warranty* will be charged as a non-warranty repair and billed at Panasonic's current rate for parts and labor.

*See the warranty stipulations in these instructions.

**Replacement program excludes Puerto Rico and is subject to termination at any time without advance notice.



Matsushita Consumer Electronics Company, Division of Matsushita Electric Corporation of America
One Panasonic Way, Secaucus,
New Jersey 07094

Panasonic Sales Company, Division of Matsushita Electric of Puerto Rico, Inc. ("PSC")
Ave. 65 de Infantería, Km. 9.5
San Gabriel Industrial Park, Carolina,
Puerto Rico 00985